

VIDEO CASSETTE RECORDER OWNER'S GUIDE

HIGH DEFINITION DIGITAL VCR



MODEL HS-HD1100U



VCR Plus and PlusCode are registered trademarks of Gemstar Development Corporation. The VCR Plus+ system is manufactured under license from Gemstar Development Corporation.



This Video Cassette Recorder is based on the D-VHS and VHS formats. Only video cassette tapes with the **D-VHS** mark or the **VHS** mark may be used with this model. However, D-VHS recordings are possible only with cassettes marked **D-VHS**.



D-VHS tapes recorded on video products not using the D-VHS MTP/NTSC standard cannot be played back on this unit.

Special Features HS-HD1100U

- ◆ High-Definition Digital Recording and Playback
- ◆ IEEE 1394 Interface for Digital Home Networking
- ◆ Rew/FF at 500X speed (:43 seconds for a T-120 tape)
- ◆ S-VHS quasi playback
- ◆ PerfectTape®

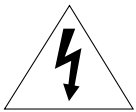

The lightning flash with arrowhead symbol, within an equilateral triangle, is intended to alert the user to the presence of uninsulated “dangerous voltage” within the product’s enclosure that may be of sufficient magnitude to constitute a risk of electric shock to persons.



The exclamation point within an equilateral triangle is intended to alert the user to the presence of important operating and maintenance (servicing) instructions in the literature accompanying the product.

IMPORTANT:

RECORDING OF COPYRIGHTED TELEVISION PROGRAMS MAY VIOLATE COPYRIGHT LAW.

WARNING:

TO REDUCE THE RISK OF FIRE OR ELECTRIC SHOCK, DO NOT EXPOSE THIS PRODUCT TO RAIN OR MOISTURE.

CAUTION:

TO PREVENT ELECTRIC SHOCK HAZARD, DO NOT USE THIS (POLARIZED) PLUG WITH AN EXTENSION CORD, RECEPTACLE OR OTHER OUTLET UNLESS THE BLADES CAN BE FULLY INSERTED TO PREVENT BLADE EXPOSURE.

NOTE TO CATV SYSTEM INSTALLER:

THIS REMINDER IS PROVIDED TO CALL THE CATV SYSTEM INSTALLER’S ATTENTION TO SECTION 820-40 OF THE NEC WHICH PROVIDES GUIDELINES FOR PROPER GROUNDING AND, IN PARTICULAR, SPECIFIES THAT THE CABLE GROUND SHALL BE CONNECTED TO THE GROUNDING SYSTEM OF THE BUILDING, AS CLOSE TO THE POINT OF CABLE ENTRY AS PRACTICAL.

SHORTCUTS

To **connect** your VCR, go to page 4.

To **play a tape**, go to page 11.

To **record a program**, go to page 20.

To learn about **Advanced Features**, go to page 42.

TABLE OF CONTENTS

IMPORTANT SAFEGUARDS	2	Editing Features	38
Hooking Up Your VCR.....	4	Copying a Tape from D-VHS to D-VHS	38
Playback	11	Copying a Tape from D-VHS to Analog	39
Setting Up Your VCR.....	15	Copying a Tape from Analog to Analog	40
Memorizing Channels Automatically	15	Advanced Features	42
Adding and Deleting Channels	16	Advanced Playback Controls	42
Setting the Clock.....	17	Searching Techniques	43
Recording	20	Displaying Time Gauge, Remaining	
Recording a Current Digital Broadcast ..	20	Time, Current Time	46
Recording a Current Broadcast in VHS		Customize Choices Menu	47
(analog) Format	22	Advanced Options	50
OTR	23	Location of Controls	52
OTR ²	24	Important Information	56
Notes about Available Tape and Recording		Trouble Checks	57
Time	25	Specifications	59
Using Audio and Video Functions	26	Index	59
Timer Recording	28	Warranty	62
D-VHS (digital) Timer Recording	28		
VHS (analog) Timer Recording of Digital			
Broadcast.....	29		
Conventional VCR Timer Recording	31		
VCR Plus+® System Programming	33		
Quick Program	34		
Timer Recording Hints	35		

IMPORTANT SAFEGUARDS

Please read all these instructions carefully regarding your VCR before you begin operating it. Follow all warnings and instructions marked on the VCR. Thank you.

1 Read Instructions

All the safety and operating instructions should be read before the product is operated.

2 Retain Instructions

The safety and operating instructions should be retained for future reference.

3 Heed Warnings

All warnings on the product and in the operating instructions should be adhered to.

4 Follow Instructions

All operating and use instructions should be followed.

5 Cleaning

Unplug this product from the wall outlet before cleaning. Do not use liquid cleaners or aerosol cleaners. Use a damp cloth for cleaning.

6 Attachments

Do not use attachments not recommended by the product manufacturer as they may cause hazards.

7 Water and Moisture

Do not use this product near water — for example, near a bath tub, wash bowl, kitchen sink, laundry tub, in a wet basement, or near a swimming pool, and the like.

8 Accessories

Do not place this product on an unstable cart, stand, tripod, bracket, or table. The product may fall, causing serious injury to a child or adult, and serious damage to the product. Use only with a cart, stand, tripod, bracket, or table recommended by the manufacturer, or sold with the product. Any mounting of the product should follow the manufacturer's instructions, and should use a mounting accessory recommended by the manufacturer.

9 A product and cart combination should be moved with care. Quick stops, excessive force, and uneven surfaces may cause the product and cart combination to overturn.



10 Ventilation

Slots and openings in the cabinet are provided for ventilation and to ensure reliable operation of the product and to protect it from overheating, and these openings must not be blocked or covered. The openings should never be blocked by placing the product on a bed, sofa, rug, or other similar surface. This product should not be placed in a built-in installation such as a bookcase or rack unless proper ventilation is provided or the manufacturer's instructions have been adhered to.

11 Power Sources

This product should be operated only from the type of power source indicated on the marking label. If you are not sure of the type of power supply to your home, consult your product dealer or local power company. For products intended to operate from battery power, or other sources, refer to the operating instructions.

12 Grounding or Polarization

This product is equipped with a polarized alternating-current line plug (a plug having one blade wider than the other). This plug will fit into the power outlet only one way. This is a safety feature. If you are unable to insert the plug fully into the outlet, try reversing the plug. If the plug should still fail to fit, contact your electrician to replace your obsolete outlet. Do not defeat the safety purpose of the polarized plug.

13 Power-Cord Protection

Power-supply cords should be routed so that they are not likely to be walked on or pinched by items placed upon or against them, paying particular attention to cords at plugs, convenience receptacles, and the point where they exit from the product.

14 Outdoor Antenna Grounding

If an outside antenna or cable system is connected to the product, be sure the antenna or cable system is grounded so as to provide some protection against voltage surges and built-up static charges.

Article 810 of the National Electrical Code, ANSI/NFPA 70, provides information with regard to proper grounding of the mast and supporting structure, grounding of the lead-in wire to an antenna discharge unit, size of grounding conductors, location of antenna-discharge unit, connection to grounding electrodes, and requirements for the grounding electrode.

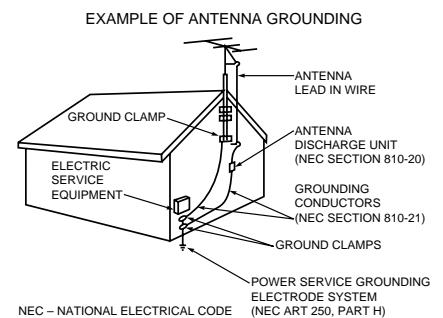

15 Lightning

For added protection for this product during a lightning storm, or when it is left unattended and unused for long periods of time, unplug it from the wall outlet and disconnect the antenna or cable system. This will prevent damage to the product due to lightning and power-line surges.

16 Power Lines

An outside antenna system should not be located in the vicinity of overhead power lines or other electric light or power circuits, or where it can fall into such power lines or circuits. When installing an outside antenna system, extreme care should be taken to keep from touching such power lines or circuits as contact with them might be fatal.

17 Overloading

Do not overload wall outlets, extension cords, or integral convenience receptacles as this can result in fire risk or electric shock.

18 Object and Liquid Entry

Never push objects of any kind into this product through openings as they may touch dangerous voltage points or short-out parts that could result in a fire or electric shock. Never spill liquid of any kind on the product.

19 Servicing

Do not attempt to service this product yourself as opening or removing covers may expose you to dangerous voltage or other hazards. Refer all servicing to qualified service personnel.

20 Damage Requiring Service

Unplug this product from the wall outlet and refer servicing to qualified service personnel under the following conditions:

- When the power-supply cord or plug is damaged.
- If liquid has been spilled, or objects have fallen into the product.
- If the product has been exposed to rain or water.

(d) If the product does not operate normally by following the operating instructions. Adjust only those controls that are covered by the operating instructions as an improper adjustment of other controls may result in damage and will often require extensive work by a qualified technician to restore the product to its normal operation.

(e) If the product has been dropped or damaged in any way.

(f) When the product exhibits a distinct change in performance – this indicates a need for service.

21 Replacement Parts

When replacement parts are required, be sure the service technician has used replacement parts specified by the manufacturer or have the same characteristics as the original part. Unauthorized substitutions may result in fire, electric shock or other hazards.

22 Safety Check

Upon completion of any service or repairs to this product, ask the service technician to perform safety checks to determine that the product is in proper operating condition.

23 Heat

The product should be situated away from heat sources such as radiators, heat registers, stoves, or other products (including amplifiers) that produce heat.

CONDENSATION

Leave the VCR on, without a tape in it, for 2 hours if the VCR has been exposed to sudden changes in temperature. Sudden temperature changes cause moisture to form on the metal parts inside the VCR. This moisture can cause the tape to stick and damage the head. Leaving the VCR on for a 2 hour period will dry the inside of the VCR.

PROTECT THE POWER CORD

Do not damage the power cord. Damage to the power cord may cause a fire or shock hazard. When unplugging the power cord, please hold it by the plug and remove it carefully.

DO NOT PLACE HEAVY OBJECTS ON THE RECORDER

Heavy objects placed on the recorder will cause damage.

WHEN NOT IN USE

When you finish operating the recorder, always unload the cassette and turn OFF the VCR POWER.

CARE OF THE VIDEO CASSETTE TAPES

- Avoid violent vibration or shock.
- Do not place in a location where strong magnetic fields exist (near a motor, transformer or magnet).
- Never place or store in direct sunlight.
- Avoid dusty places.
- Place the cassette in the cassette case and store vertically.
- Never store tape in a high humidity location.

INFORMATION

This equipment has been tested and found to comply with the limits for a Class B digital device, pursuant to Part 15 of the FCC Rules. These limits are designed to provide reasonable protection against harmful interference in a residential installation. This equipment generates, uses, and can radiate radio frequency energy and, if not installed and used in accordance with the instructions, may cause harmful interference to radio communications. However, there is no guarantee that interference will not occur in a particular installation. If this equipment does cause harmful interference to radio or television reception, which can be determined by turning the equipment off and on, try to correct the interference by one or more of these measures:

- Reorient or relocate the receiving antenna
- Increase the separation between the equipment and receiver
- Connect the equipment into an outlet on a different circuit than the receiver is connected
- Consult the dealer or an experienced radio/TV technician for help

Changes or modifications not expressly approved by the party responsible for compliance could void the user's authority to operate the equipment. If necessary, consult the dealer or an experienced radio/TV technician for additional suggestions. You may find this booklet prepared by the Federal Communications Commission helpful: [How to Identify and Resolve Radio-TV Interference Problems](#). This booklet is available from the US Government Printing Office, Washington, D.C., 20402, Stock No. 004-000-00345-4.

Hooking Up Your VCR

Unpacking Your VCR

As you unpack your new VCR, please make sure the following items are included:

- Remote control

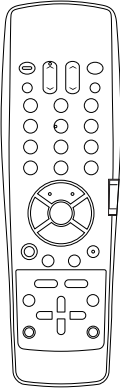

- 1 Audio/Video cable

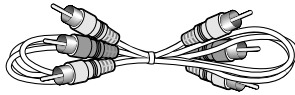

- 1 Coaxial cable

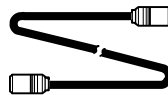

- IEEE 1394 cable



- 2 "AA" size batteries



- Registration card



IMPORTANT

Never place any heavy objects on top of the VCR. Use caution when placing the VCR on top of the television as the surface may not be stable.

Choosing a Hookup

The connections shown in this book are general. Individual televisions and stereo systems can vary from those shown here. The first diagrams show connections for common equipment. Then, if you are connecting equipment such as an integrated HDTV, an IEEE 1394-equipped HDTV receiver or a Home Theater receiver, you will also use those diagrams after you have connected the common equipment.

IMPORTANT

To maximize your system for its best performance, your dealer can help you customize these hookups and sell you any additional connection accessories that may be necessary to match your particular equipment and antennas.

- 1 Make a list of each piece of equipment that you want to hook up.
- 2 If you are connecting several pieces of equipment, you may be using more than one of these diagrams. Using your list, find EACH of the diagrams you will need to connect all of your equipment. For example, to hook up this VCR, a TV, a cable box, and a Home Theater receiver, you will use Cable System with Cable Box, and Connecting a Home Theater receiver.
- 3 If your TV has audio and video inputs, use the diagrams on page 7 in addition to the connections on page 5 or 6.

Hooking Up Your VCR

IMPORTANT

You must use one of the connections shown on page 5 and 6 in order to record television or cable programs.

Antenna or Cable System without Cable Box

Connecting Antenna or Cable

- 1 Connect antenna or cable from wall outlet to ANTENNA IN of the VCR.
- 2 Connect VCR ANTENNA OUT to the TV's Antenna jacks (varies by TV).
- 3 If your TV has audio video inputs, continue with the connections on page 7. If not, plug in power cords of VCR and TV.

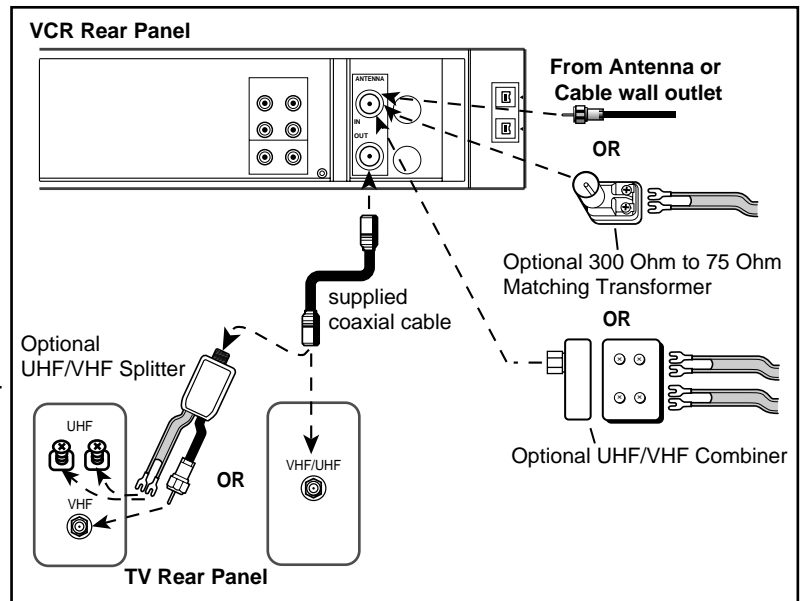

Antenna or Cable System with Cable Box

Connecting Cable and Cable Box, if all channels are scrambled

- 1 Connect cable from wall outlet to CABLE IN on the cable box.
- 2 Connect OUT (or OUT TO TV) on the cable box to ANTENNA IN on the VCR.
- 3 Connect ANTENNA OUT on the VCR to the TV's antenna jacks (varies by TV).
- 4 If your TV has audio video inputs, continue with the connections on page 7. If not, plug in power cords of VCR, TV, and cable box.

If your cable company scrambles all of its channels, you cannot record one channel while watching another.

If your cable company only requires the use of a cable box for some channels, connect the cable box as shown on the next page.

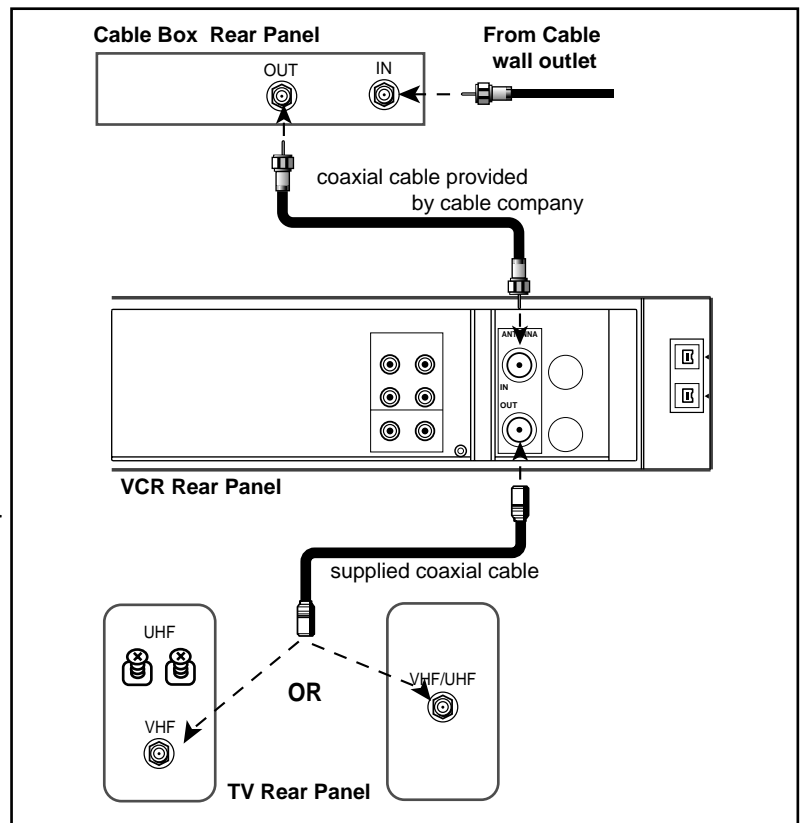

IMPORTANT

Your TV Owner's Guide may have additional suggestions for antenna/cable hookups.

If your TV has more than one antenna jack, ask your Mitsubishi dealer for advice on additional accessories.

Hooking Up Your VCR

Connecting Cable and Cable Box, if only some channels are scrambled

- 1 You will need a cable splitter, five lengths of coaxial cable, and a cable A/B switch.
- 2 Connect cable from wall outlet to IN terminal on the cable splitter.
- 3 Connect the coaxial cable to OUT terminal on the cable splitter and A-IN on the A/B switch.
- 4 Connect the second coaxial cable to the other OUT terminal on the splitter and IN (or CABLE) on the cable box.
- 5 Connect the third coaxial cable to the OUT or TV on the cable box and B-IN on the A/B switch.
- 6 Connect the fourth coaxial cable to OUT terminal on the A/B switch and ANTENNA IN on the VCR.
- 7 Connect the fifth coaxial cable to the ANTENNA OUT on the VCR to the TV's ANTENNA jacks (varied by TV).
- 8 If your TV has audio and video inputs, continue with the connections on the next page. If not, plug in power cords of VCR, TV, and cable box.

This connection will allow you to watch one non-scrambled channel while you record another non-scrambled channel.

With this connection, you should set the A/B switch to A to record a non-scrambled channel. You may watch the same channel or any other non-scrambled channel at the same time.

To record a scrambled channel, set the switch to B, select your cable output channel (usually 3 or 4) on the VCR and select the channel you wish to record on the cable box. At this time your TV will not be able to show any other channel.

IMPORTANT

With this connection, you cannot:

- record a scrambled channel and watch a non-scrambled channel at the same time.
- record a non-scrambled channel and watch a scrambled channel at the same time.
- record one scrambled channel and watch a different scrambled channel.

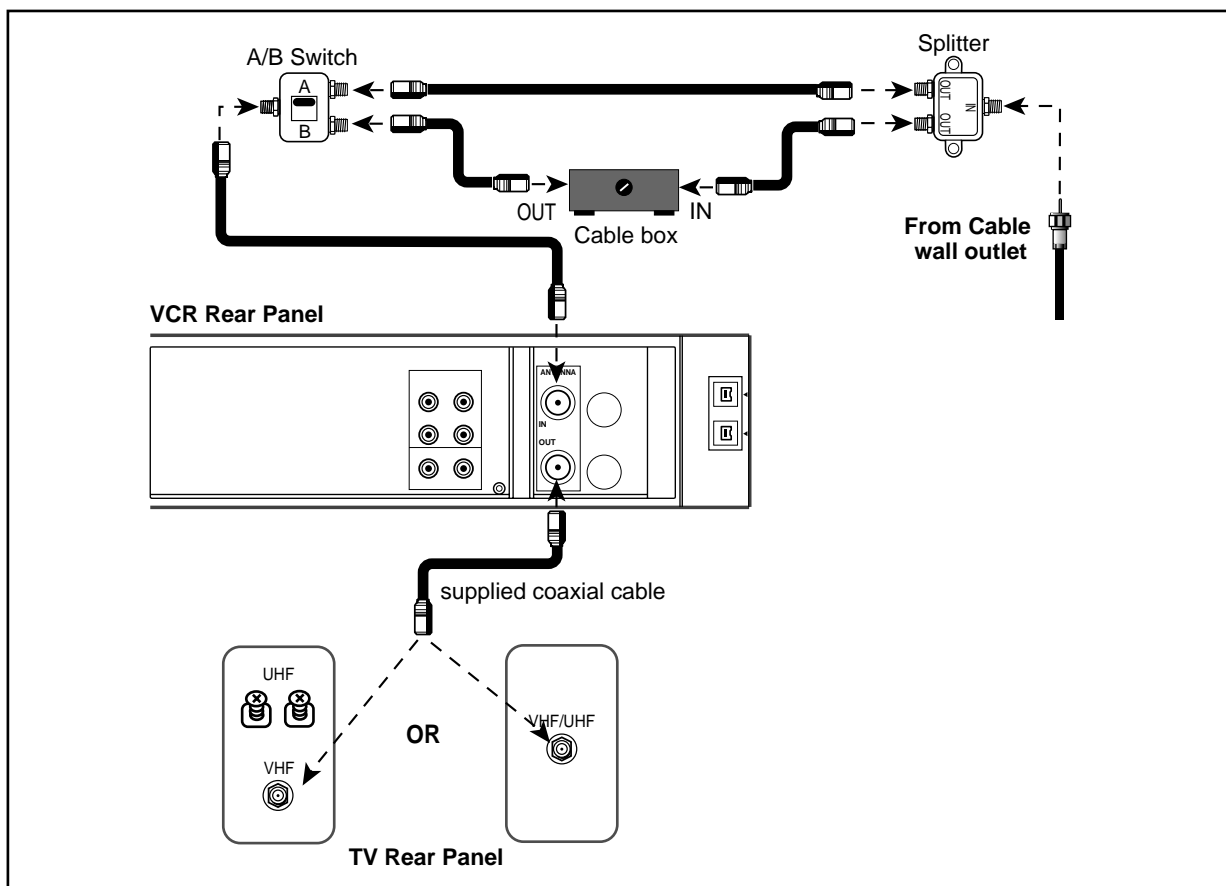

Hooking Up Your VCR

Connections to TV with Audio Video Inputs

Because you purchased a Hi-Fi VCR, you will want to take advantage of its superior sound capability and connect it to a stereo TV system with audio and video inputs. This connection also helps maintain the best picture quality.

- 1 Connect the red and white audio cable to AUDIO OUT R (right) and AUDIO OUT L (left) on the VCR. Connect the other end to the TV's AUDIO INPUT RIGHT and AUDIO INPUT LEFT. Match the colors of the connectors to the cables.
- 2 Connect the yellow video cable to VIDEO OUT on VCR. Connect the other end to VIDEO INPUT on the TV.
- 3 Set the RF converter to OFF. See page 48 for instructions on this setting, which can be done at a later time.

IMPORTANT

Your TV Owner's Guide may have additional suggestions for audio video hookups.

To connect your VCR to a mono (non-stereo) TV, connect only the white AUDIO OUT L of the VCR and the white AUDIO INPUT of the TV. Since the TV is not stereo, you cannot take advantage of your VCR's Hi-Fi stereo sound.

If you have an older TV without audio video inputs, simply connect only the antenna or cable as shown on page 5 or 6.

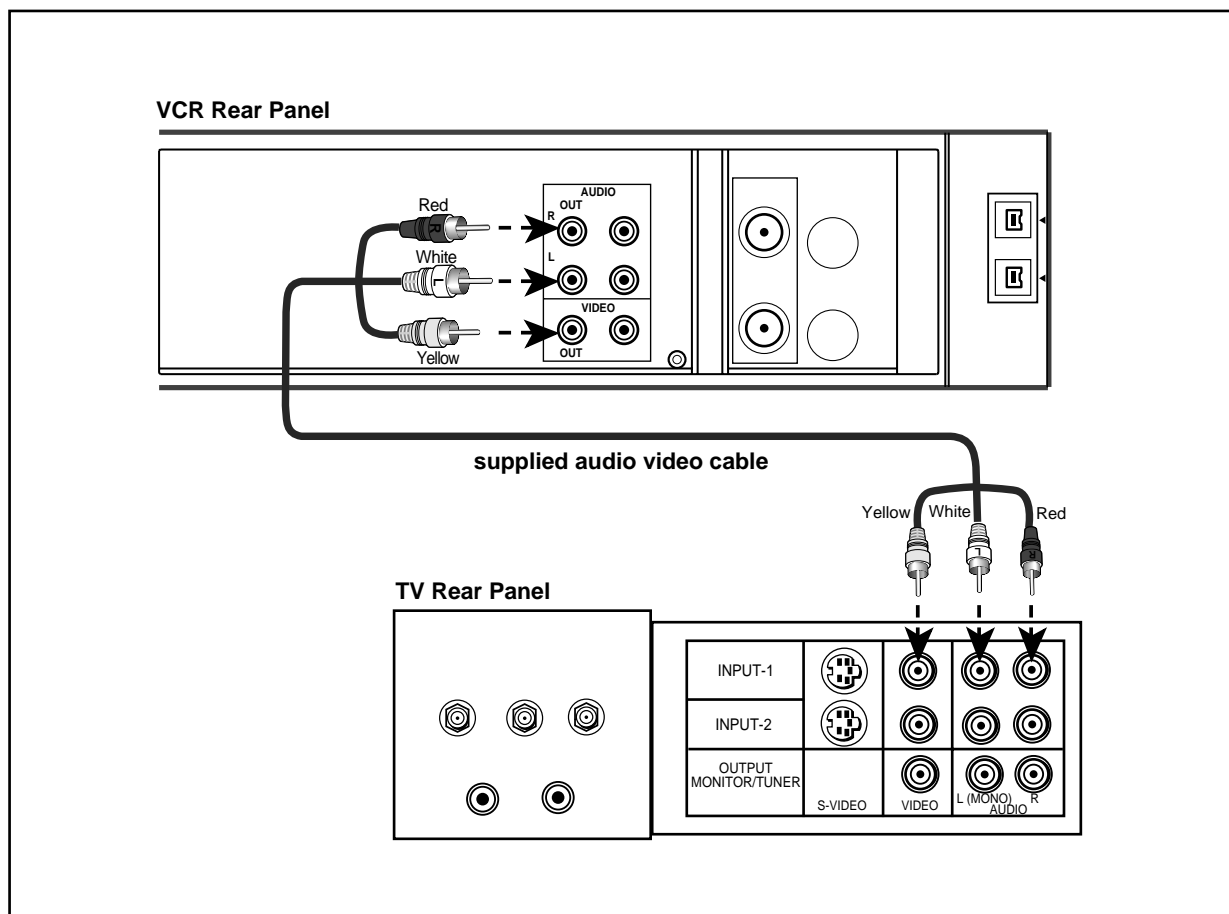

Hooking Up Your VCR

Connections to Integrated HDTV or IEEE 1394-equipped HDTV Receiver

If you connect the HS-HD1100U to an integrated HDTV or an IEEE 1394-equipped HDTV receiver with an IEEE 1394 cable, you can record digital broadcasts in D-VHS format, which records digital broadcasts as digital signals, so programs can be recorded as is with no loss of quality. And this connection also makes it possible to playback a recorded digital signal in D-VHS format.

- 1 Connect the supplied IEEE 1394 cable to IEEE 1394 INTERFACE on the HS-HD1100U. You can connect either of the two IEEE 1394 INTERFACE terminals. Connect the other end of this cable to IEEE 1394 INTERFACE terminal on the TV or the receiver.

When you want to record digital broadcasts in VHS (analog) format, follow the steps 2 and 3 below.

- 2 Connect the red and white audio cable to AUDIO IN R (right) and AUDIO IN L (left) on the VCR. Connect the other end to the TV or the receiver's AUDIO OUTPUT RIGHT and AUDIO OUTPUT LEFT. Match the colors of the connectors to the cables.

- 3 Connect the yellow video cable to VIDEO IN on the VCR. Connect the other end to VIDEO OUTPUT on the TV or receiver.

IMPORTANT

You may need to purchase additional sets of audio and video cable for this hookup.

Refer to your integrated HDTV or IEEE 1394-equipped HDTV receiver owner's guide for these connections.

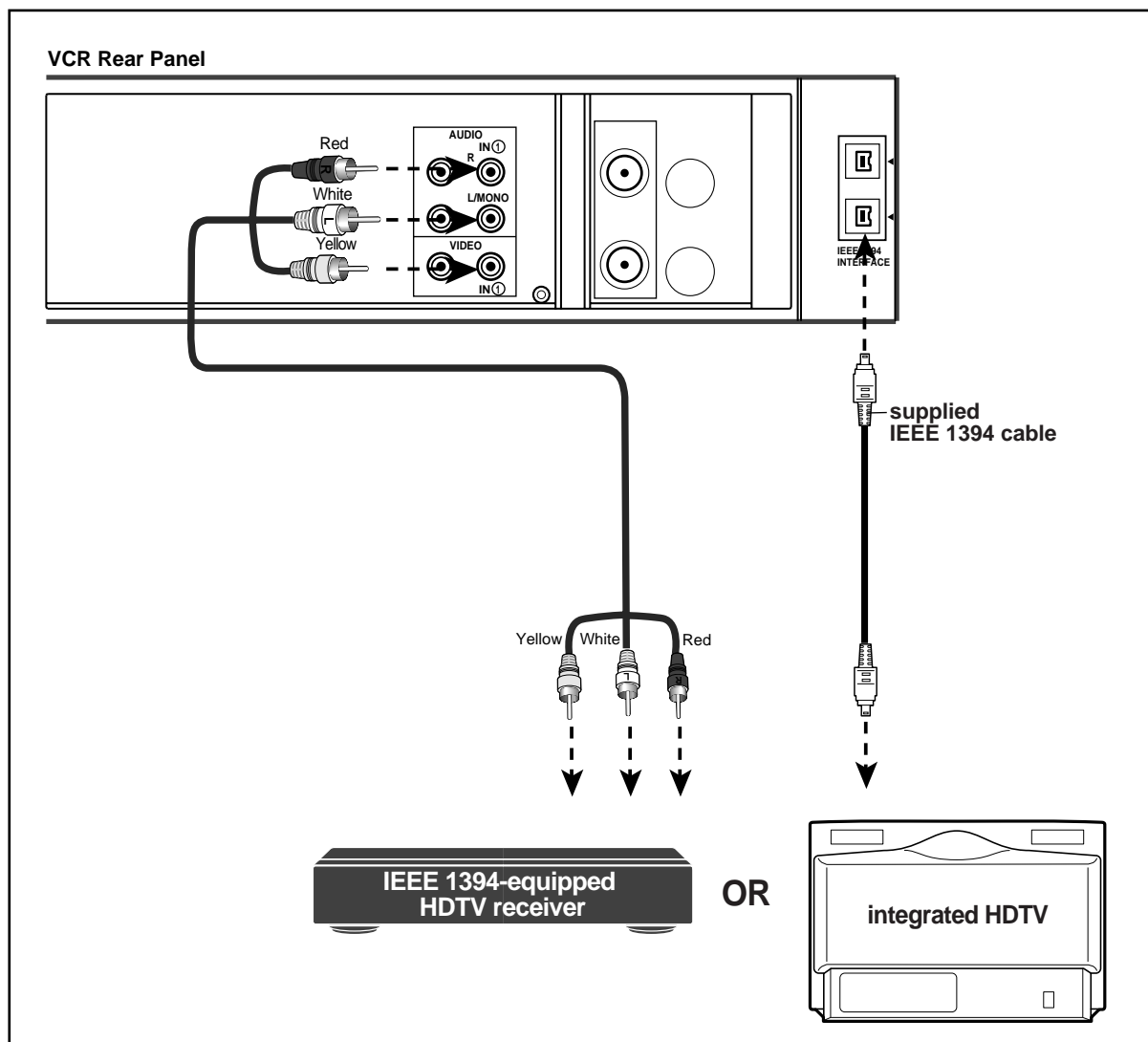

Hooking Up Your VCR

Notes about IEEE 1394 network

The IEEE 1394-equipped devices that are available to be connected to the HS-HD1100U are an integrated HDTV, an IEEE 1394-equipped HDTV receiver or another D-VHS VCR. The data may not be sent/received correctly if you are connecting IEEE 1394-equipped devices other than Mitsubishi integrated HDTV or Mitsubishi D-VHS VCR.

You cannot send/receive the data of digital video equipment (for example, digital video camera) or a personal computer because the format is different from that of the HS-HD1100U.

Be sure not to connect the IEEE 1394 in a loop, as shown below.

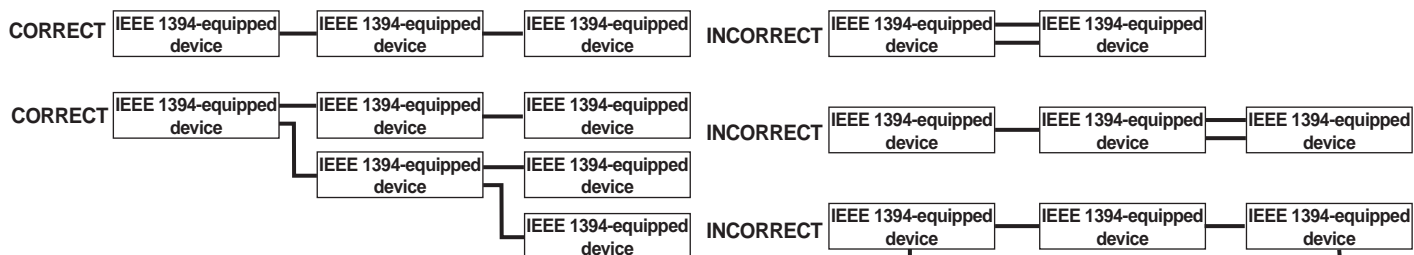

When you connect more than one IEEE 1394-equipped devices, turn the power off when they are not being used because leaving the unused devices turned on may cause a lack of memory and may interfere with the correct transmission of signals. However, some IEEE 1394-equipped devices cannot receive or send data when it is turned off, so refer to your device owner's guides.

While using the IEEE 1394-equipped device, do not plug in/off the IEEE 1394 cable or turn the power on/off of the unused devices. When you unplug the IEEE 1394 cable and connect it again, leave it unplugged for a few seconds and then connect again.

The maximum transmit speed of the IEEE 1394 INTERFACE on the HS-HD1100U is 400Mbps. This speed may be slower when you connect another device and its transmit speed is different from this VCR.

Hooking Up Your VCR

Connections to Home Theater Receiver

You may wish to connect your VCR to a Home Theater Receiver so that you can take advantage of the Surround Sound audio recordings that are common with many movies. Home Theater Receivers will often control both the sound that is heard from the speakers and the picture shown on your TV. Below is the basic connection between your VCR and Home Theater Receiver. If you use this connection, you will not use **Connections to TV with Audio Video Inputs**.

- 1 Connect the red and white audio cables to AUDIO OUT R and AUDIO OUT L on the VCR. Connect the other end to the VCR 1 AUDIO INPUT R and AUDIO INPUT L on the Home Theater Receiver.
- 2 Connect a yellow video cable to VIDEO OUT on the VCR. Connect the other end to the VCR 1 VIDEO INPUT on the Home Theater Receiver.

- 3 Connect a yellow video cable to the MONITOR VIDEO OUTPUT of the Home Theater Receiver. Connect the other end to the VIDEO INPUT on the back of the TV.
- 4 See your Home Theater Receiver Owner's Guide for information concerning audio connection between TV and Home Theater Receiver, or additional hookups and operations.

IMPORTANT

You may need to purchase additional sets of audio and video cables for this hookup.

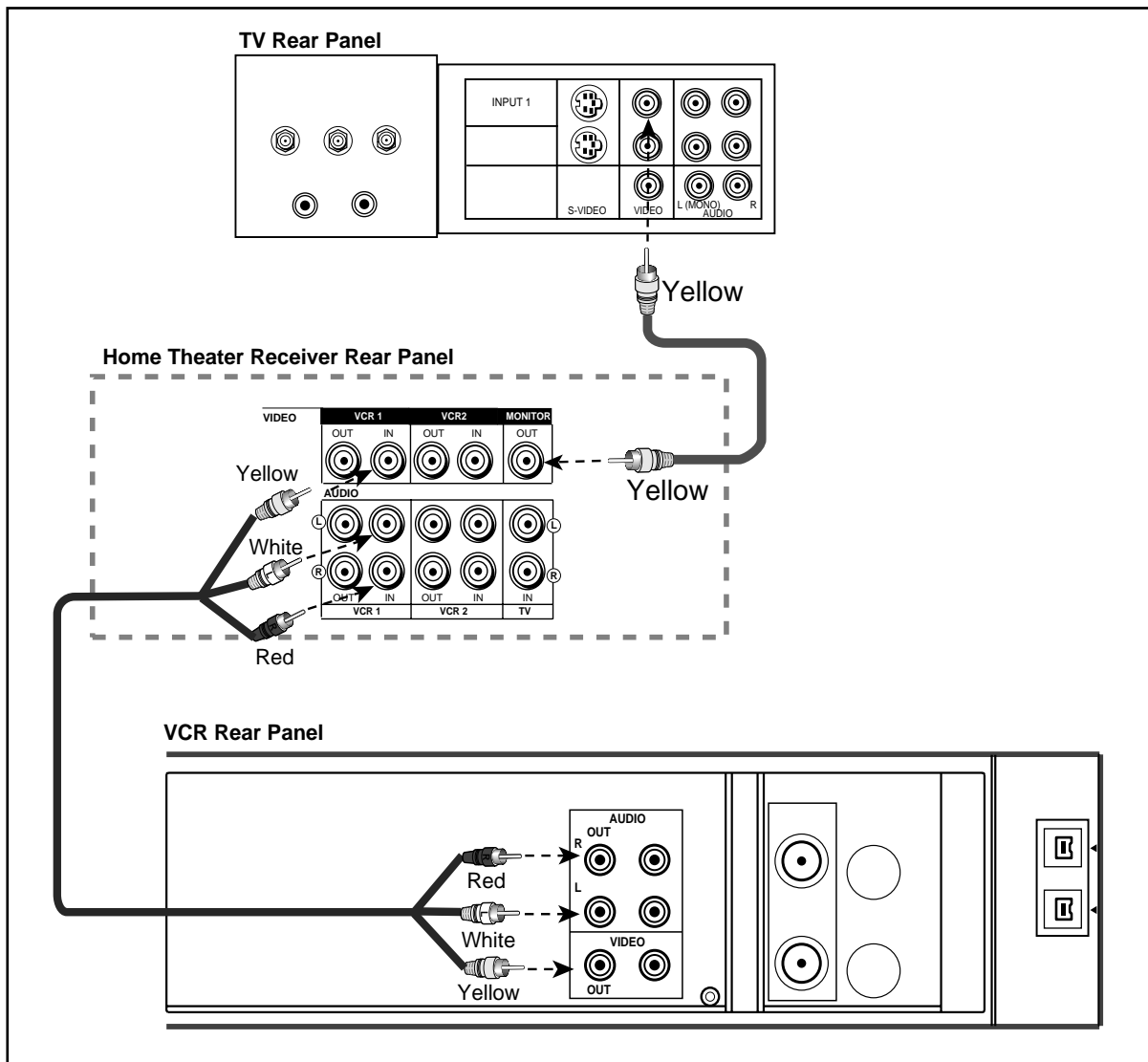

Playback

Setting Up Your VCR to Playback/Recording the Digital Broadcast in D-VHS (digital) Format

- 1 Make sure that your VCR and the integrated HDTV or the IEEE 1394-equipped HDTV receiver is connected with an IEEE 1394 cable.
- 2 Turn on the IEEE 1394-equipped HDTV receiver.
- 3 Turn on your TV and switch the input of the TV to the correct input of the IEEE 1394-equipped HDTV receiver.
- 4 Press POWER on the VCR to turn the power on.

To go back to viewing the picture from the TV, set your TV input to the previous ANTENNA input position.

If you do not switch the integrated HDTV or the IEEE 1394-equipped HDTV receiver to the correct external input, the screen to the right will be displayed on the screen when you try to watch a digital broadcast.

1394 connection list

When you connect an integrated HDTV, an IEEE 1394-equipped HDTV receiver or a D-VHS VCR to the HS-HD1100U, you can see the list of connected TVs, receivers or VCRs on the 1394 connection list menu (up to 5 devices). The integrated HDTV and the IEEE 1394-equipped HDTV receiver will be displayed as TUNER, and the D-VHS VCR will be shown as VCR. For the device which was connected to the HS-HD1100U before but now it is not connected, lost connection will be displayed. The device which was first connected to the HS-HD1100U will be shown as d1, and connected fifth will be shown as d5. When you want to remake the list, press CANCEL on the VCR remote control. In this case, the order of the devices on the list will be changed.

IMPORTANT

When you connect Mitsubishi integrated HDTVs, for example, WS-55859, WS-65869, WS-55909, WS-65909 or WS-73909, they will be displayed as - - - - in 1394 connection list menu. When you use these TVs, they will control the HS-HD1100U. So to use the function of the HS-HD1100U, use the TV to operate the VCR.

displaying 1394 connection list

- 1 Press MENU on the remote control. VCR Main Menu comes up.
- 2 Press the ADJUST buttons on the remote control to select 1394 connection list. Press ENTER. 1394 connection list menu appears.

Setting Up Your VCR to Playback/Recording the Tape in VHS (analog) Format

The first thing you need to do is set up your VCR so that you can see the picture coming from the VCR. It's important to take a few minutes to set up your VCR correctly before you try to use it. Based on the type of TV that you have, choose one of the following:

TV with Audio/Video Inputs

- 1 Turn on your TV and switch it to the correct external input. For most Mitsubishi TVs, this means pressing the TV's INPUT button until you see the words **Ext-1** or **Input-1** on the screen. If you do not have a Mitsubishi TV, please refer to your TV Owner's Guide for this procedure.
- 2 Turn the VCR on by pressing POWER.

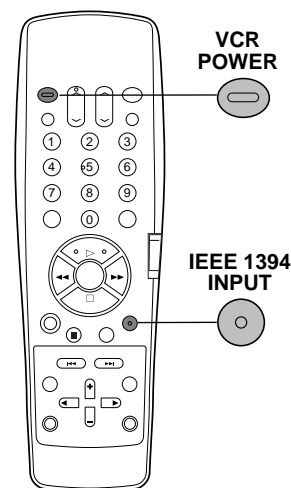

This is a digital recording.
You cannot view it through this input.

Please select IEEE1394 connection

1394 connection list
d1 TUNER lost connection
d2 TUNER lost connection
d3 TUNER now connecting
d4 TUNER now connecting

Press CANCEL to renumber
Use ADJUST to select,
and ENTER.
Press MENU to go back.

VHS PWR. HS STD VCR
- - H - - M - - S d3

Playback

- 3 You are now watching the VCR's picture. To go back to viewing the picture from the TV, press the TV's INPUT button to go back to the previous ANTENNA input position.
- 4 Later, you should turn the RF converter OFF by following instructions on page 48.

If your system includes a home theater receiver or an A/V receiver, refer to your home theater receiver's owner's guide.

TV without Audio/Video Inputs

If your TV does not have separate audio/video inputs, then your VCR will need to convert the VCR's picture to channel 3 or 4. This is called the video channel. The factory has already selected channel 3; however, if it is a broadcast channel in your area, then you will need to change this to channel 4. To make this change:

set up

- 1 To choose channel 4: with VCR power OFF, turn the front panel jog dial disk clockwise while holding down the SP/EP button on the front panel. **Ant ch 4** will display on the front panel and the VCR will send signals on channel 4.

If needed, to return to channel 3: with the VCR turned OFF, turn the jog dial counter-clockwise while holding down the SP/EP button on the front panel. **Ant ch 3** will display.

- 2 Turn the VCR on by pressing POWER.

operating

- 3 Check to see if the VCR light on the front panel display is lit. If it is not, press VCR/TV on the remote control until the VCR light appears on the front panel. This light must be on when you watch a video tape or use the VCR menus. The VCR light will turn on automatically when you play a tape or use the VCR menus when the RF converter is set to ON. See page 48.
- 4 Turn on the TV and change the TV to the video channel (3 or 4). You are now watching the VCR's picture.

To watch a channel that is different than the channel your VCR is recording, the VCR light must be off. The VCR/TV button turns this light on and off.

Operating Your Remote Control

Installing the Batteries

- 1 To remove the back cover, press the ridged area gently, then push the cover in the direction of the arrow and lift.
- 2 Load the batteries, making sure the polarities (+) and (-) are correct. This is marked inside the battery compartment.

Next, you need to tell the remote control to operate the VCR, not the TV.

Operating the VCR with the Remote Control

The HS-HD1100U has two VCR remote control operational settings: VCR-A and VCR-B. The HS-HD1100U is pre-set to VCR-A setting. See page 51 for information about VCR operational setting.

- 1 Set the VCR/TV slide switch on the remote control to VCR position. This "tells" the remote that you want to control the VCR.

Now your remote is ready to operate your HS-HD1100U. If the VCR does not respond to the remote, please see page 51.

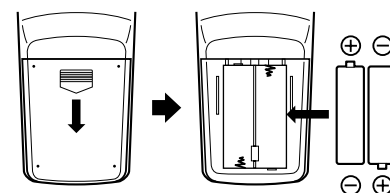
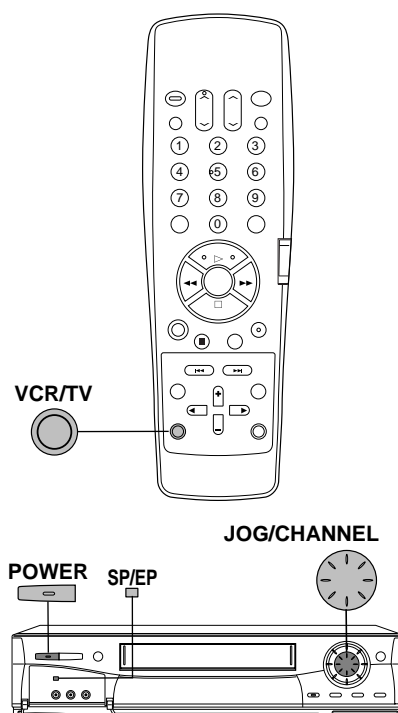

Playback

Loading a Tape

Tapes can be loaded into your VCR as long as the VCR is plugged in. Even when the VCR POWER is off, loading a tape will automatically turn the VCR on. Use only tapes that have a **DVHS**, **VHS** or **SVHS** label.

- 1 Hold the tape so that the long narrow edge with the contents label faces you. The other edge is hinged and should face the VCR. The plastic window that shows the videotape should face up.
- 2 Gently insert the tape evenly into the cassette slot until the VCR automatically takes it in.

If the VCR will not automatically take the tape in, press EJECT and try again.

Your VCR will eject the tape if it is loaded improperly. If the VCR ejects the tape, remove the tape, check to see that the contents label is facing you, that the geared tape reels are facing down, wait a few seconds, and try again.

Playing a Tape

Playing a Tape Recorded in D-VHS Format

- 1 When you connect an integrated HDTV or IEEE 1394-equipped HDTV receiver which is capable of controlling the VCR:
Operate your TV or receiver to playback the tape. Refer to the TV or receiver owner's guide for this procedure.

When you connect an integrated HDTV or IEEE 1394-equipped HDTV receiver which is not capable of controlling the VCR:

Set the connection setting of your TV or receiver to select the HS-HD1100U.

Refer to the TV or receiver owner's guide for this procedure.

And then press PLAY on the front panel or the remote control of the VCR.

You can stop playing by pressing STOP.

It will take a few seconds to display the playback picture. A mosaic noise, still or black picture will appear until the correct picture comes on. When the VCR reaches the end of the tape, it will automatically rewind to the beginning of the tape and stop.

When you playback the end of a recording, the point where the recording mode changes or a broken part of the tape, a mosaic noise, still or black picture may appear.

The tape recorded in D-VHS format on other VCR may not be played back correctly on this VCR.

Playing a Tape Recorded in Analog Format

- 1 Press PLAY on the front panel or the remote control.

The VCR will automatically play the tape at the correct speed. When the VCR reaches the end of the tape, it will automatically rewind to the beginning of the tape and stop.

You can stop playing by pressing STOP.

You can playback a tape recorded in S-VHS format with standard VHS resolution (S-VHS quasi playback). This feature functions only during playback. You cannot obtain the original resolution of S-VHS.

Depending on the tapes you are using, some interference may appear on the screen during S-VHS quasi playback.

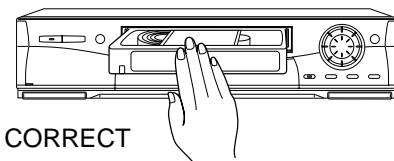

CORRECT

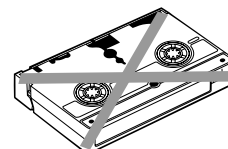

INCORRECT

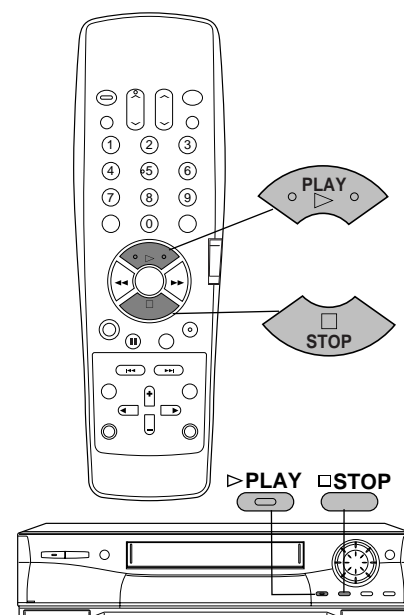

Playback

Using Basic Playback Controls

Rewinding a Tape

While the tape is stopped, press REW on the remote control or turn the shuttle ring on the front panel to the left.

Fast Forwarding a Tape

While the tape is stopped, press FF on the remote control or turn the shuttle ring on the front panel to the right.

Speed Search with Picture

While the tape is playing, press FF on the remote control or turn the shuttle ring on the front panel to the right for forward speed search with picture, or press REW on the remote control or turn the shuttle ring on the front panel to the left for reverse speed search. See page 44 for additional information on searching techniques.

Pausing a Tape

While the tape is playing, press PAUSE on the remote control or on the front panel to freeze the picture on the screen.

Press PAUSE a second time to return to normal play.

If you leave the VCR in pause for more than 5 minutes, the VCR will automatically stop to prevent damage to the tape.

When pausing a tape recorded in D-VHS format, a black picture may appear before the still picture appears depending on the integrated HDTV or IEEE 1394-equipped HDTV receiver.

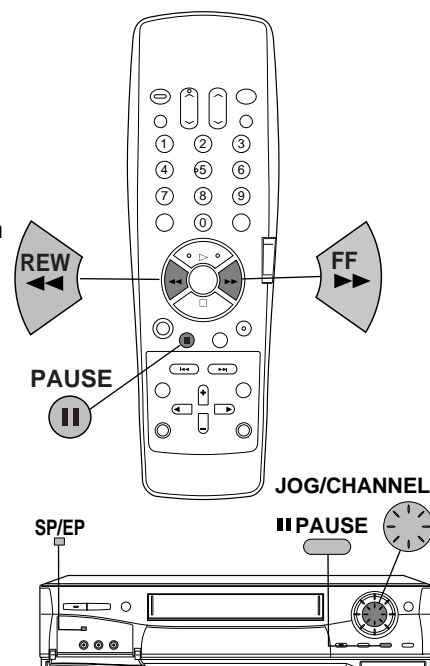

Unloading a Tape

- 1 Press EJECT on the front panel or on the remote control. If the VCR POWER is off, the VCR will turn on, eject the tape, then turn off.
- 2 Remove the tape.

Using Repaired Tapes

We recommend that you take any broken or torn tapes to a professional for repair. If you repair a torn tape with improper materials, you could damage your VCR when you play the tape.

Head Cleaning

Your VCR automatically cleans the head and the drum of the VCR whenever you load a tape. If you see mosaic noise, still or black picture during D-VHS playback, or “noise” or snow during analog playback, eject the tape, re-load the tape, then wait 3 or 4 seconds. Repeat this process several times to improve the picture.

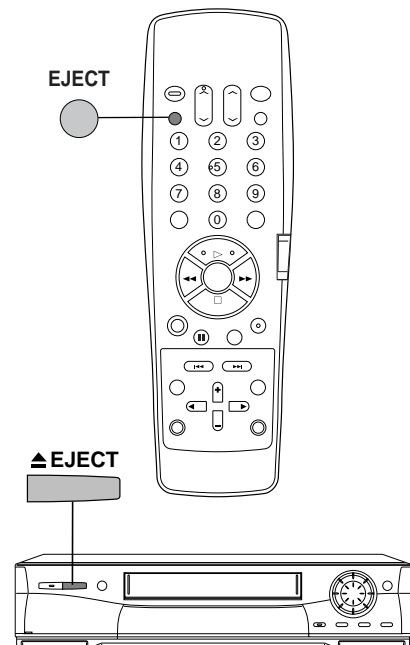

Setting Up Your VCR

Your VCR comes with Mitsubishi's exclusive **ViewPoint®** on-screen operating system. This system has been developed to simplify the operation of your VCR with clear, easy-to-understand language and design.

Before your VCR can receive television channels or you can program your VCR to record, you need to memorize all of the channels you can receive into your VCR and set the clock. Fortunately, your VCR makes this an easy process with our menu system.

When using the on-screen menus, use the ADJUST buttons to move the highlight bar up or down and to change the setting of selected features. Press the ENTER button to enter a selection or adjustment. Press the CANCEL button to cancel or clear a setting.

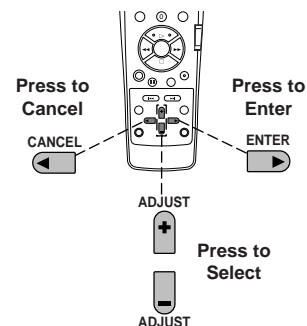

Memorizing Channels Automatically

Using this process, your VCR will automatically memorize all of the television stations available to you. You can later get rid of unwanted or unused stations.

If your local cable company scrambles some or all stations, and/or requires you to use a cable box, then your ability to program channels would normally be limited. The cable box receives all of your channels, then sends only one to your TV and your VCR, usually on channel 3 or 4.

If your cable box or cable system seems incompatible with your new VCR, call your cable company. They may be able to provide solutions to your problems.

A special note to cable box subscribers

- 1 Set the VCR's input to tuner. To do this, press INPUT on the remote control until a channel number appears on the screen.
- 2 Press MENU on the remote control. VCR Main Menu comes up. If First Time Set-Up is not highlighted, use the ADJUST buttons on the remote to highlight it.

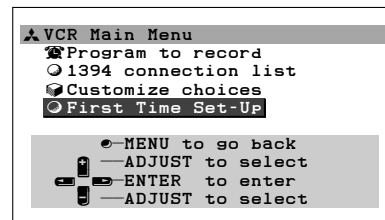

- 3 Press ENTER. First Time Set-Up menu will appear. Press the ADJUST buttons to select Memorize channels. Press ENTER.

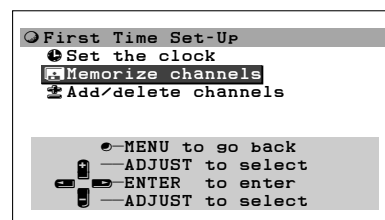

IMPORTANT

If you are playing back a tape or receiving a video signal from an external input, **Not available** will flash and an error message will appear. To correct this, stop the tape or turn off the menus and switch the VCR's input to Tuner.

- 4 You will see the menu for sources connected to the VCR. Using the list below as a reference, press the ADJUST buttons to select the kind of antenna you connected.
 - **Cable** if you are using any cable combination, including a cable box with an A/B switch
 - **Indoor/outdoor ant.** if you use "rabbit ears" or a roof mounted antenna
 After you have selected, press ENTER.
- 5 An on-screen message will show you that the VCR is memorizing the stations you can receive. You can cancel the memorization at any time by pressing CANCEL. After the VCR has memorized all the channels, the screen will return to the VCR's picture.

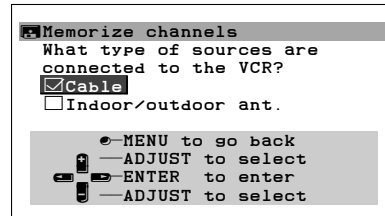

IMPORTANT

Automatic channel memorizing may include vacant channels if there are stray signals or noise on those channels. If this occurs, you can manually delete the channels using the procedure in the section **Adding an Deleting Channels**.

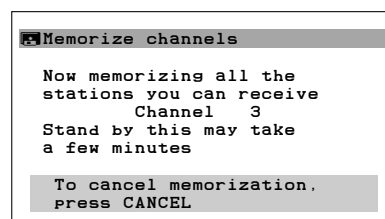

Setting Up Your VCR

Adding and Deleting Channels

If necessary, you can manually add or delete channels after you have completed the automatic channel memorization.

- 1 Make sure that video mute is ON. See page 47.
- 2 Set the VCR's input to Tuner. To do this, press INPUT on the remote control until a channel number appears on the screen or the front panel display.
- 3 Press MENU on the remote control. VCR Main Menu appears.
- 4 Press the ADJUST buttons on the remote control to select First Time Set-Up. Press ENTER.
- 5 You will see the First Time Set-Up menu. Press the ADJUST buttons to select Add/delete channels. Press ENTER.

IMPORTANT

If you are playing back a tape or receiving a video signal from an external input, Not available will flash on-screen. To correct this, stop the tape or turn off the menus and switch the VCR's input to Tuner.

- 6 You will see the screen for adding or deleting channels. Press the ADJUST buttons to select the channel that you want to add or delete. Press ENTER to add the channel; press CANCEL to delete it.
- 7 When you are finished adding or deleting channels, press MENU three times to exit the menus.

IMPORTANT

If you use automatic memorization again, you will lose all of the manual changes you made. All of the channels you deleted will be added; all of the channels you added will be deleted.

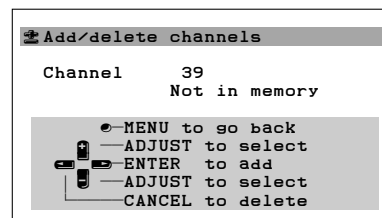
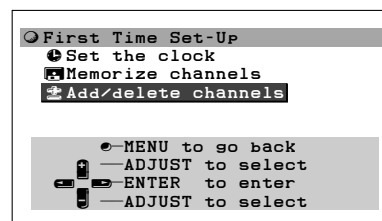

Selecting a Channel

Now that you have memorized channels, and added or deleted some, you will want to be able to select channels. If you have not yet memorized channels, see page 15, **Memorizing Channels Automatically**.

Antenna/Cable selections
indoor/outdoor antenna
cable antenna

Your VCR can receive
VHF/UHF channels 2–69
cable channels 1–125

If you try to select a channel number that the VCR cannot receive, the VCR will not change channels.

selecting channels sequentially

Press CHANNEL on the remote control or turn the jog dial on the VCR front panel. This will cycle through the channels in sequential numerical order.

selecting antenna, cable or digital cable channels directly

Use the number buttons on the remote control. For example, to choose channel 23, press 2-3.

To select a single digit channel, such as channel 5; press 0-5. You can also press 5, then press ENTER.

Setting Up Your VCR

Setting the Clock

You have to set the clock using either **Setting the Auto Clock** or **Setting the Clock Manually**.

Setting the Auto Clock

Your VCR can set the clock automatically by picking up a time signal which some TV and cable channels transmit with their broadcasts. Most PBS stations send this signal; however, this function works only if a channel in your area is broadcasting a time signal. If you don't receive this signal, set the clock manually.

- 1 Press MENU on the remote control. VCR Main Menu will appear.
- 2 Press the ADJUST buttons to select First Time Set-Up. Press ENTER. The First Time Set-Up menu will appear. Use the ADJUST buttons to select Set the clock. Press ENTER.
- 3 You will see the Set the clock menu. Auto clock set will be highlighted. Press the ADJUST buttons to select ON.
- 4 Turn the VCR off to activate the Auto Clock setting function.

The VCR will search for a channel that carries a time signal, then set your time zone and daylight saving time. If there are only a few channels in your area that carry time signals, it may take about 30 minutes to complete. If you turn the VCR on before the correct time displays, the Auto Clock setting will be cancelled. See if the clock has been set on the front panel display on the VCR.

If the VCR displays the wrong time, the time zone setting may not be correct. To adjust this, follow the steps in **If the VCR displays the wrong time**. (See the next page.)

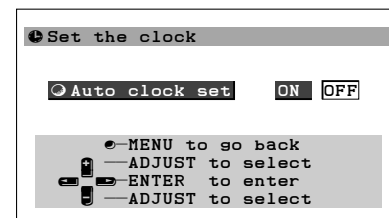
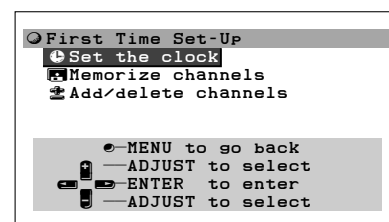

IMPORTANT

The auto clock function will activate whenever you turn off the VCR and at 3:00 am, when the VCR power is off. If you use a cable box, make sure that you leave the cable box on and tuned to the local PBS station to activate the auto clock function.

After a power failure, the VCR will automatically set the clock again. (If you have set the Auto clock set setting of the Set the clock menu to OFF, the Auto Clock function will not work.)

Setting Up Your VCR

If the VCR displays the wrong time

- 1 Follow the procedure on the previous page to step 3. Press ENTER.
- 2 You will see the Set the clock menu. Channel will be highlighted. If you know the channel that carries a time signal, press the ADJUST buttons to enter the channel. Most PBS stations broadcast a time signal. For the quickest response, enter your local PBS station. If you don't know it, leave the channel setting at AUTO. Press ENTER.
- 3 Time zone will be highlighted. Press the ADJUST buttons to select the time zone of your area. Available time zones are: Atlantic, Eastern, Central, Mountain, Pacific, Alaska, and Hawaii. Press ENTER.
- 4 Daylight savings will be highlighted. Press the ADJUST buttons to select AUTO, ON or OFF. If you follow daylight saving time, select ON. If not, select OFF. If you select AUTO, the VCR automatically sets the daylight saving time.
- 5 To activate the auto clock function, turn off the VCR.

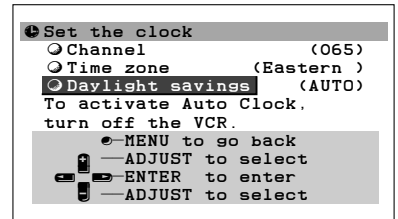
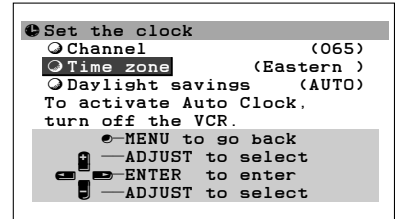
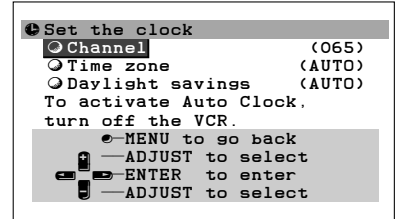

Setting the Clock Manually

Skip this section if your VCR has set the clock correctly using the Auto Clock function.

- 1 Press MENU on the remote control. You will see the VCR Main Menu.
- 2 Press the ADJUST buttons to select First Time Set-Up. Press ENTER. First Time Set-Up menu will appear. Press the ADJUST buttons to select Set the clock. Press ENTER.
- 3 You will see the Set the clock menu. Auto clock set will be highlighted. Press the ADJUST buttons to select OFF. Press ENTER.
- 4 Daylight savings will be highlighted. Press the ADJUST buttons to select ON or OFF. If you are currently following daylight savings, select ON. Otherwise, select OFF. Press ENTER.

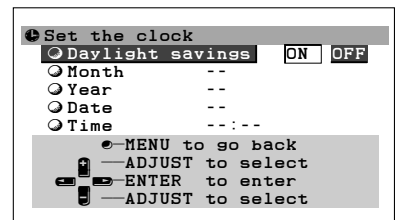
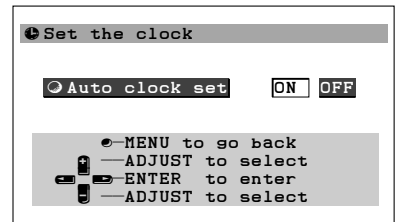

Setting Up Your VCR

5 Press the ADJUST buttons until the correct month appears on screen. Press ENTER.

6 Press the ADJUST buttons to set the current year. Press ENTER.

7 Press the ADJUST buttons to set the date. Press ENTER.

8 The hour numbers and the am/pm indicator will be blinking. Press the ADJUST buttons to set the hour and am/pm at the same time. Pressing ADJUST + moves the clock *forward*; pressing ADJUST - moves the clock *backward*. Press ENTER.

9 Press the ADJUST buttons to set the minutes. When you have set the correct time, press ENTER. First Time Set-Up menu will appear, and the clock will start running.

10 Press MENU twice to turn off the menus.

You can adjust the daylight saving time manually. When Daylight savings is highlighted, press the ADJUST buttons to select ON or OFF.

If you select ON, the VCR will set the clock forward one hour.

If you select OFF, the VCR will set the clock back one hour.

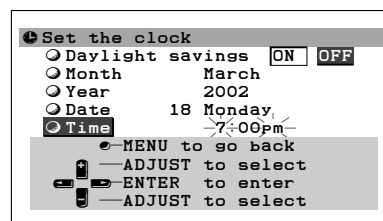
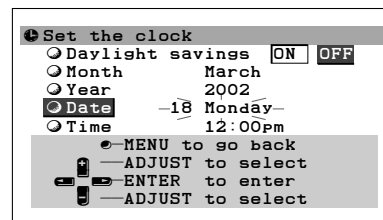
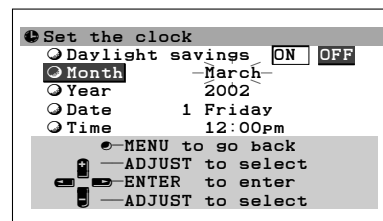

IMPORTANT

Any time you adjust this setting, check your programmed recordings to be sure they are set to the correct times.

Recording

Your new VCR offers a wide variety of recording options that take full advantage of our advanced electronics. First, you can learn how to record a current broadcast. Then, in another section of this book called **Timer Recording**, you can learn how to program your VCR to record at a later time and day.

Recording a Current Digital Broadcast

Recording a Current Digital Broadcast in D-VHS (digital) Format

- 1 Follow the steps 1 to 4 of **Setting Up Your VCR to Playback/Recording the Digital Broadcast in D-VHS (digital) Format** on page 11.
- 2 Select the channel you would like to record on the integrated HDTV or the IEEE 1394-equipped HDTV receiver, not on the VCR.
- 3 Load a D-VHS tape with its erasure prevention tab intact into the VCR.
- 4 Make sure that the D-VHS button on the front panel is lit. If not, press this button until it lights up.
- 5 When you are connecting the integrated HDTV or the IEEE 1394-equipped HDTV receiver which is capable of controlling the VCR:
Operate your TV or receiver to record, to pause recording or to stop recording. Refer to the TV or receiver owner's guide for this procedure. During your TV or receiver is operating the HS-HD1100U, d1 to d5 that corresponds to that TV or receiver will be displayed on the front panel display.

When you are connecting the integrated HDTV or the IEEE 1394-equipped HDTV receiver which is not capable of controlling the VCR:

Press IEEE 1394 INPUT on the VCR remote control to select the device you would like to record from. d1 to d5 will appear on the front panel display. Select the number that corresponds to the device from which you would like to record. And then press REC on the remote control or on the front panel.

Recording will start. When the VCR reaches the end of the tape, it will automatically rewind to the beginning of the tape and stop.

- You can stop recording at any time by pressing STOP or PAUSE on the remote or on the front panel.
 - To resume recording from STOP, press REC.
 - To resume recording from PAUSE, press PAUSE.
- You cannot use REC/(2)REC LENGTH on the front panel to resume recording from PAUSE.

IMPORTANT

Refer to your integrated HDTV or IEEE 1394-equipped HDTV receiver owner's guide.

The recording mode will be changed automatically depending on the broadcasting signal.

While the VCR is recording a digital broadcast, please do not change the channel on the integrated HDTV or the IEEE 1394-equipped HDTV receiver.

If you pause the VCR for more than five minutes, recording will stop automatically to protect the tape.

If you pause a recording, a mosaic noise, a still or a black picture may appear when playing where the recording is resumed.

If you attempt to record on a tape that has had its erasure prevention tab removed, the VCR will eject it. To record over such a tape, simply place a piece of vinyl tape over the opening.

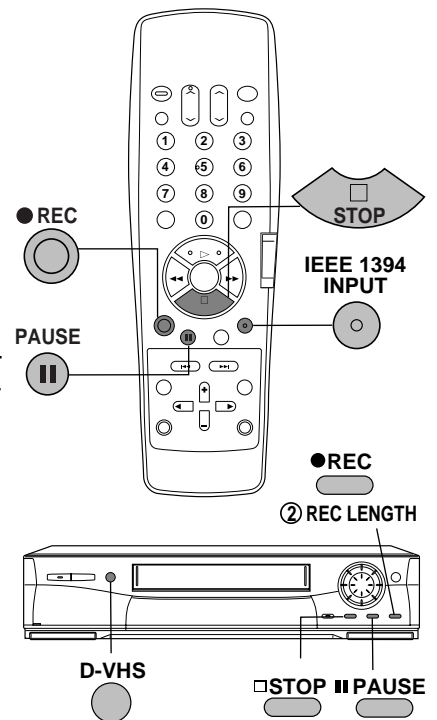

Recording

recording copy protected digital programs

Some programs have copy protect data to prohibit or restrict recording.

- Programs without copy protection : D-VHS recording is available.
- Programs with copy restriction : You can record in D-VHS format once, but cannot copy.
- Programs prohibited from copying: D-VHS recording is not available.

When you record the program prohibited from copying or copy the program with copy restriction, no COPY will appear on the front panel display.

no COPY will also appear when recording without receiving broadcasting signal. If this occurs, check the hook up.

Recording a Current Digital Broadcast in VHS (analog) Format

- 1 Select the channel you would like to record on the integrated HDTV or the IEEE 1394-equipped HDTV receiver, not on the VCR.
- 2 Load a tape with its erasure prevention tab intact into the VCR.
- 3 Press INPUT to select the external input to the position which is connected to the integrated HDTV or the IEEE 1394-equipped HDTV receiver.
 - select **L1** if you connect to the rear panel.
 - select **L2** if you connect to the front panel.
- 4 Select the speed at which you would like to record by pressing SP/EP on the remote control or on the front panel.
- 5 Press REC on the remote or REC/② REC LENGTH on the front panel.

Recording will start. When the VCR reaches the end of the tape, it will automatically rewind to the beginning of the tape and stop.

- You can stop recording at any time by pressing STOP or PAUSE on the remote or on the front panel.
 - To resume recording from STOP, press REC.
 - To resume recording from PAUSE, press PAUSE.
- You cannot use REC/② REC LENGTH on the front panel to resume recording from PAUSE.

IMPORTANT

Be sure to connect the VCR and an integrated HDTV or an IEEE 1394-equipped HDTV receiver with a video and an audio cable to record a digital broadcast in analog format.

While the VCR is recording a digital broadcast, please do not change the channel on the integrated HDTV or the IEEE 1394-equipped HDTV receiver.

The menu or the program list of an integrated HDTV or an IEEE 1394-equipped HDTV will be recorded if it is displayed during recording.

If you pause the VCR for more than five minutes, recording will stop automatically to protect the tape.

If you record a digital broadcast in analog format, the picture quality will not be as clear as that of the original digital broadcast.

If you record a copy protected digital program, the copy protect data will also be recorded.

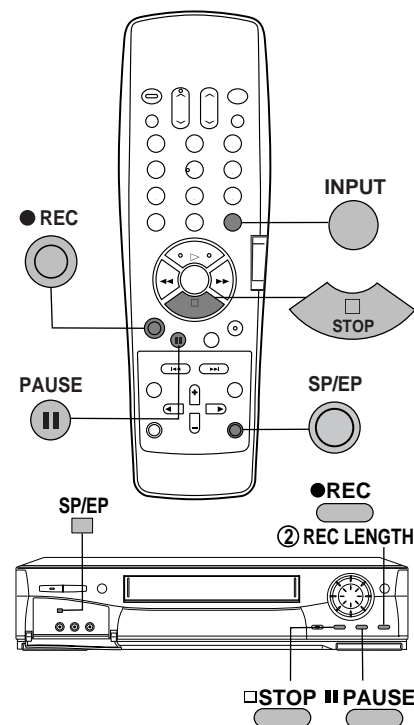

Recording

Recording a Current Broadcast in VHS (analog) Format

- 1 Load a tape with its erasure prevention tab intact into the VCR.
- 2 Select the speed at which you would like to record by pressing SP/EP on the remote control or on the front panel.
- 3 Set the VCR's input to Tuner by pressing INPUT until a channel number is shown on-screen or on the front panel display. If **L1** or **L2** appears instead of a channel number, continue to press INPUT until a channel number appears.
- 4 Select the channel you wish to record by pressing CHANNEL or the number buttons on the remote or the jog dial on the front panel. If you are using a cable box, select channel 3 or 4 on the VCR, and change the channel on the cable box, not on the VCR. Additionally, if you are using an A/B switch, remember to set the switch to the correct position.
- 5 Press REC on the remote or REC/②REC LENGTH on the front panel.

Recording will start. When the VCR reaches the end of the tape, it will automatically rewind to the beginning of the tape and stop.

- You can stop recording at any time by pressing STOP or PAUSE on the remote or on the front panel.
 - To resume recording from STOP, press REC.
 - To resume recording from PAUSE, press PAUSE.
- You cannot use REC/②REC LENGTH on the front panel to resume recording from PAUSE.

IMPORTANT

If you pause the VCR for more than five minutes, recording will stop automatically to protect the tape.

If you record in extended play (EP), you will only be able to play the tape on a VCR equipped for EP play, such as this one.

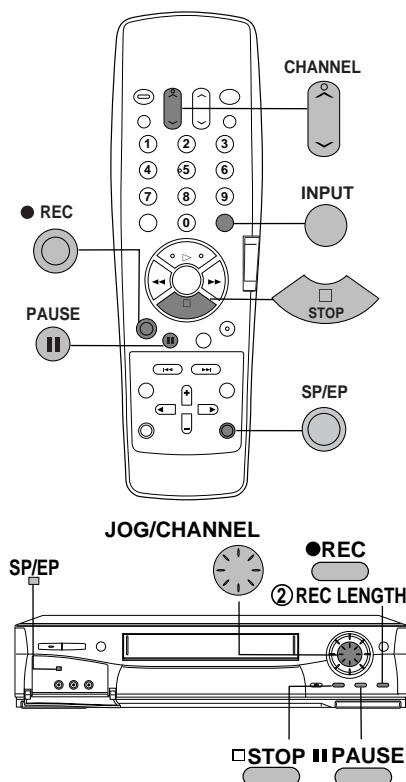

Recording

Using One-Touch Recording (OTR)

One-Touch Recording (OTR) is a way to begin recording immediately and have your VCR stop recording and turn off automatically after your show is over.

- 1 When you record a digital broadcast in D-VHS (digital) format, follow the steps 1 to 4 on page 20. And then press IEEE 1394 INPUT on the VCR remote control to select the device you would like to record from. d1 to d5 will appear on the front panel display. Select the number that corresponds to the device from which you would like to record.
When you record a digital broadcast in VHS (analog) format, follow the steps 1 to 4 on page 21.
When you record an analog broadcast in VHS (analog) format, follow the steps 1 to 4 on page 22.
- 2 Press REC/②REC LENGTH on the front panel twice. The first time you press the button, recording will begin. The second press of the same button adds 30 minutes to the OTR timer, displayed on the front panel.
- 3 Press REC/②REC LENGTH for each additional 30 minutes you want to add to the OTR timer, up to 4 hours. If you press REC/②REC LENGTH 10 times, you will see End on the front panel display. The VCR will record until the end of the tape. If you press REC/②REC LENGTH an eleventh time, the VCR will resume normal manual recording.

The OTR timer will begin to count down backwards. When it reaches zero, the VCR will stop recording and turn off. The OTR light on the front panel display will light up during the OTR recording.

If you program too much time into the OTR timer

Continue pressing REC/②REC LENGTH. After the End point you can start over from zero, adding time in 30 minute intervals.

How OTR affects other controls

If you press PAUSE during OTR, the VCR will pause recording, but the OTR timer continues to count down.

Press PAUSE again to resume recording from the record-pause mode. The REC/②REC LENGTH will not resume your recording.

If you press STOP during OTR, you erase the OTR programming.

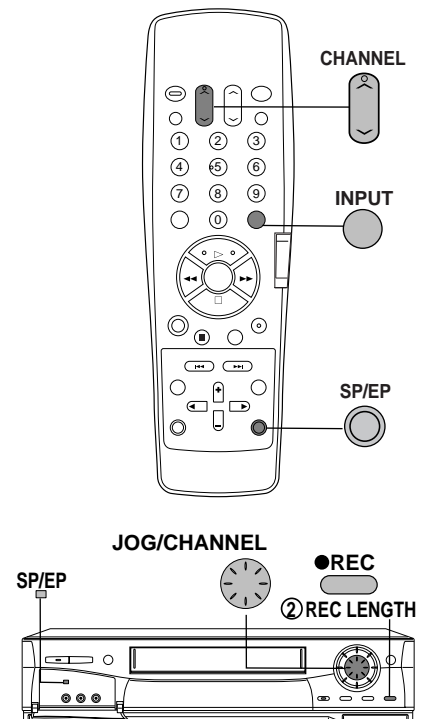

Recording

Using Standby One-Touch Recording (OTR²)

Standby One-Touch Recording (also called OTR²) is a programming method to begin recording within the next 24 hours and record in 30 minutes intervals. Before you use OTR², make sure the clock has been set correctly.

- 1 Load a tape with its erasure prevention tab intact into the VCR.
- 2 Select the speed at which you would like to record by pressing SP/EP on the remote control or on the front panel.
- 3 Set the VCR's input to Tuner by pressing INPUT until a channel number is shown on-screen or on the front panel display. If **L1** or **L2** appears instead of a channel number, continue to press INPUT until a channel number appears.
- 4 Press CHANNEL or the number buttons on the remote or the front panel jog dial to choose the channel to be recorded. If you are using a cable box, select channel 3 or 4 on the VCR, and change the channel on the cable box. Additionally, if you are using an A/B switch, remember to set the switch to the correct position.
- 5 Press PAUSE/①START TIME on the front panel to set the time when you wish recording to start (within 24 hours). The start time is displayed on the front panel. The first time display is the next half-hour increment from the current time. For example, if it is currently 2:15, 2:30 (next half-hour increment) will be displayed. Similarly, if it is currently 2:40, 3:00 (again, the next half-hour increment) will be displayed. Each time you press the button, the start time is delayed by 30 minutes.
- 6 Press REC/②REC LENGTH for each additional 30 minutes you want to add to the OTR² timer, up to 4 hours. If you see End on the front panel display, the VCR will record until the end of the tape.

After 30 seconds, the power will turn off and the programmed recording light will be lit. The VCR will automatically turn on at the OTR² start time and recording will begin. When the OTR² timer reaches zero, the VCR will stop recording and turn off automatically. If the end of the tape is reached before OTR² is finished, the VCR will stop and the power will turn off.

IMPORTANT

Other programs you have set to record may be erased if:

- the start times are before the OTR² start time
- conflicts with the OTR²
- starts within one minute or less after the OTR² finishes

If you turn the power on while your VCR is in stand-by for the OTR², the OTR² programming will be erased.

To cancel OTR²

- Turn the power OFF while you are programming the timer.
- Turn the power ON if you have finished programming the timer.

How OTR² affects other controls

If you press REC/②REC LENGTH on the front panel during OTR² recording, 30 minutes will be added to the OTR² timer. If you press STOP during OTR² recording, you erase the OTR² programming.

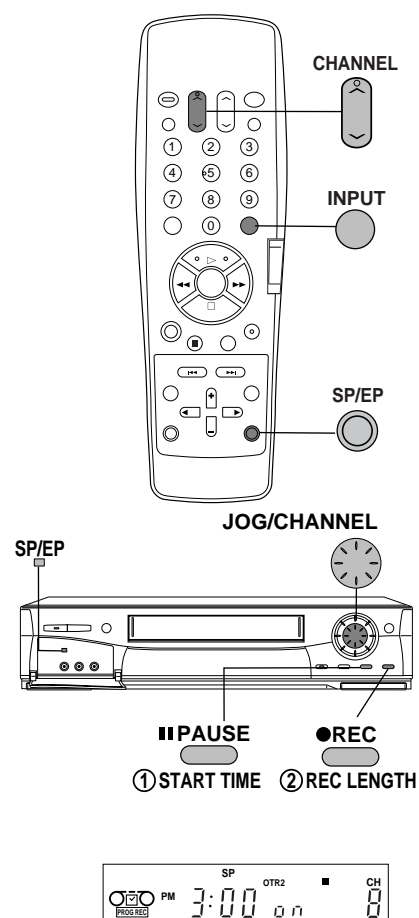

Recording

Notes about Available Tape and Recording Time

Recording Format

The available recording format is as follows:

Recording format	Tape	
	D-VHS	VHS
D-VHS	Yes	No
VHS	Yes	Yes

When you use a D-VHS tape for D-VHS recording, the recording format is preset to D-VHS format.

Recording Mode

The available recording mode is as follows:

Recording format	Digital recording mode		Analog recording mode	
	HS	STD	SP	EP
D-VHS	Yes	Yes		
VHS			Yes	Yes

HS (high speed) : You can record the half duration of STD.

STD (standard) : You can record the same duration as described on the tape.

SP (standard play) : You can record the same duration as described on the tape.

EP (extended play) : You can record the duration as three times as described on the tape.

When you record a digital broadcast in D-VHS format, the recording mode will be changed automatically depending on the broadcast signal of the recorded program. For VHS recording, set the recording mode manually by pressing SP/EP.

When playing a tape, the VCR will automatically select the recording mode.

Recording Time

The available recording time is as follows:

D-VHS tape

Recording format	Recording time (when recorded in STD/SP mode)				
	DF-240	DF-300	DF-360	DF-420	DF-480
D-VHS	4h	5h	6h	7h	8h
VHS	2h	2h 30m	3h	3h 30m	4h

VHS tape

Recording format	Recording time (when recorded in SP mode)								
	T-30	T-60	T-90	T-120	T-140	T-160	T-180	T-200	T-210
VHS	30m	1h	1h 30m	2h	2h 20m	2h 40m	3h	3h 20m	3h 30m

Recording

Using Audio and Video Functions

The audio and video function menus allow you to set things such as listening to the stereo track of your recording, or setting the tape length to have the remaining time display function work properly. The VCR will display the functions and settings on your TV screen. The first section describes the functions, the next section tells you how to adjust the functions.

<u>Audio functions</u>	<u>Video functions</u>	
audio monitor	Tape (length)	D-VHS Tape (length)
normal record	PerfectTape Select	repeat playback
	PerfectTape®	Search to blank
	counter zero stop	

Descriptions of Audio Functions

Audio monitor (Listen to):

This allows you to listen to the various audio tracks that your VCR is capable of recording.

- Choose **Stereo** to listen to both stereo channels.
- Choose **L** to listen to the left channel of a stereo track.
- Choose **R** to listen to the right channel of a stereo track.
- Mono track is lower in quality than the others. The audio monitor is automatically set to **Mono** if you are watching a tape that was not recorded in VHS Hi-Fi. Set the audio monitor to **Mono** to hear SAP signal recorded on the mono track of a Hi-Fi tape.

IMPORTANT

Surround Sound systems: If you have your VCR connected to a surround sound system, set the audio monitor to **Stereo**. Surround sound requires both left and right channels to create the rear channel effects.

When the VCR is not playing a tape, you will see the following displays on the TV screen for 3 seconds when you change the channel or press DISPLAY.

If you change the channel to:	Display
stereo broadcast	Stereo
SAP broadcast	SAP
stereo and SAP	Stereo+SAP

When the VCR is playing a tape, you will see the following displays on the TV screen for 4 seconds when you press DISPLAY.

The audio monitor you listen to	Display
Stereo	Audio Stereo
L	Audio L
R	Audio R
Mono	Audio Mono

Normal recording (Record):

When your VCR is recording, it actually records the audio portion of a program twice: once on the stereo Hi-Fi tracks, and once on the mono track. Additionally, your VCR can receive Separate Audio Program (SAP) broadcasts. A SAP broadcast is an alternative soundtrack for a program; it is often a soundtrack in another language. The SAP broadcast is recorded only on the mono track.

Use the normal recording function to record the SAP broadcast on the mono track by choosing **Stereo+SAP**. Otherwise, choose **Stereo**. In either case, the main program is recorded on the stereo Hi-Fi track. Also, if there is no SAP broadcast, the VCR will record the main program on the mono track.

Recording

Descriptions of Video Functions

Tape (Tape)

Adjust this function to ensure the accuracy of the Remaining Time display. The remaining time function does not work properly with a tape that is less than 30 minutes long.

<u>Length of tape</u>	<u>Use setting</u>
2 hours long or less (T-30 through T-120)	T-120
160 minutes (T-160)	T-160
180 minutes (T-180)	T-180
200 minutes (T-200)	T-200
210 minutes (T-210)	T-210

D-VHS Tape (D-VHS Tape)

Adjust this function to ensure the accuracy of the Remaining Time display.

<u>Length of tape</u>	<u>Use setting</u>
DF-160 through DF-300	DF-300
DF-360	DF-360
DF-420	DF-420
DF-480	DF-480

PerfectTape Select (Play PerfectTape)

This function turns on the PerfectTape Select circuitry, which automatically maximizes picture quality when playing a worn or poor quality tape. Set the switch to **Soft** to soften the picture, set it to **Sharp** to sharpen it. Set it to **Normal** when you do not want to use this feature. Use **Normal** on new or high quality tapes. If it is set to **Auto**, the VCR will automatically select the ideal setting of PerfectTape Select depending on the condition of the tape.

Counter zero stop (Counter zero stop)

This function is used to automatically fast forward or rewind to "0H00M00S" and stop the tape. See page 45 for more information on this feature.

Repeat playback (Repeat play)

Use this function to repeatedly play a section of tape between two index marks. See page 46 for more information on this feature.

Search to blank (Search to blank)

Use this function to search the beginning of the blank section of the tape. See page 46 for more information on this feature.

PerfectTape® (PerfectTape)

PerfectTape function allows you to test the quality of video tapes you will record on. After each test, the VCR adjusts its circuitry in order to make the best possible recording on your tape. See page 48 for more information on this feature.

Selecting and Adjusting the Audio and Video Functions

- 1 Press AUDIO/VIDEO on the remote control to see the function menu.
- 2 Press AUDIO/VIDEO repeatedly until the function you want to adjust appears.
- 3 Press the ADJUST buttons on the remote to adjust the setting. The functions will disappear if you do not press any buttons for 5 seconds.

IMPORTANT

The audio and video function menus do not appear:

- when the VCR menu is displayed
- during special effects playback

Tape and **D-VHS Tape** function do not appear during playback.

Play PerfectTape is displayed only during playback.

PerfectTape displays only when a tape, with its erasure tab intact, is loaded and the VCR is stopped.

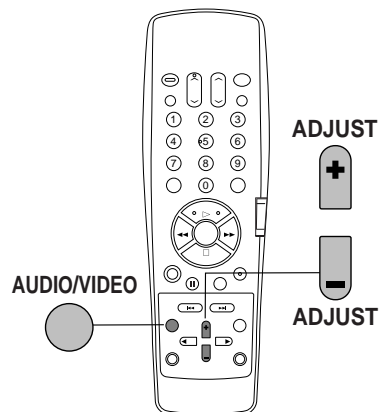

VCR
Listen to: Stereo
Use ADJUST to select

Timer Recording

Mitsubishi offers 5 ways to set your VCR to record upcoming broadcasts. Choose from:

D-VHS (digital) Timer Recording

VHS (analog) Timer Recording of Digital Broadcast

VCR Plus+ system programming (easy)

Conventional VCR timer recording

Quick Program (easy) -- VCR does not need to be on to begin programming

You can schedule up to 8 recording events within a one month period.

Clock must be set before **any** timer recordings can be performed.

D-VHS (digital) Timer Recording

To set the timer recording of the digital broadcast in D-VHS format, set the timer recording on the integrated HDTV or on the IEEE 1394-equipped HDTV receiver, not on the VCR. Refer to your TV or receiver owner's guide.

- 1 Follow the steps 1 to 4 of **Setting Up Your VCR to Playback/Recording the Digital Broadcast in D-VHS (digital) Format** on page 11.
- 2 Load a D-VHS tape with its erasure prevention tab intact into the VCR.
- 3 Make sure that the D-VHS button on the front panel is lit. If not, press this button until it lights up.
- 4 Press POWER on the VCR front panel or on the remote control to turn off the VCR.
- 5 Set the timer recording on the integrated HDTV or on the IEEE 1394-equipped HDTV receiver. Refer to your TV or receiver owner's guide for this procedure.

The integrated HDTV or the IEEE 1394-equipped HDTV receiver will receive the program to be recorded on the start time you have set and send the signal to start recording to the VCR. The VCR will start recording automatically. The integrated HDTV or the IEEE 1394-equipped HDTV receiver will send the signal to stop recording to the VCR on the end time you have set, and the VCR will stop recording automatically.

IMPORTANT

The recording mode will be changed automatically depending on the broadcasting signal.

Depending on your integrated HDTV or IEEE 1394-equipped HDTV receiver, the programmed D-VHS recording may not be recorded if you turn on the VCR while it is in stand-by mode for the D-VHS timer recording.

The programmed D-VHS timer recording may not be recorded correctly depending on your integrated HDTV or IEEE 1394-equipped HDTV receiver.

When you connect more than one integrated HDTV or IEEE 1394-equipped HDTV receiver, the D-VHS timer recording of only one integrated HDTV or IEEE 1394-equipped HDTV receiver will be activated. In this case, while the VCR is in stand-by mode for the D-VHS timer recording, press INPUT on the VCR remote to set the VCR's input to the Tuner or press IEEE 1394 INPUT to select d1 to d5 which corresponds to the receiver or the TV from which you would like to record.

Timer Recording

When you program both the D-VHS (digital) and VHS (analog) timer recording

When you turn the VCR off, the programmed recording light will appear on the front panel display, showing that the VCR is in stand-by mode for the VHS timer recording. In this mode, the D-VHS timer recording you have set may not be recorded depending on the integrated HDTV or IEEE 1394-equipped HDTV receiver that you are using (Refer to your TV or receiver owner's guide for the details.). To cancel the standby mode, press POWER on the VCR front panel once. When you press POWER, the programmed recording light will be turned off and the VCR power will remain off. Please note that the VCR cannot activate the VHS timer recording while the programmed recording light is turned off.

When the D-VHS timer recording is over, press POWER on the front panel twice to turn on the programmed recording light.

VHS (analog) Timer Recording of Digital Broadcast

IMPORTANT

Be sure to connect the VCR and an integrated HDTV or an IEEE 1394-equipped HDTV receiver with a video and audio cable to record a digital broadcast in VHS format.

- 1 Select the channel you would like to record on an integrated HDTV or an IEEE 1394-equipped HDTV receiver, not on the VCR.
- 2 Load a tape with its erasure prevention tab intact into the VCR.
- 3 Press MENU. VCR Main Menu appears on your screen. Use the ADJUST buttons to select Program to record. Press ENTER.

If there is at least one programmed recording already entered, you will see the Recap screen. Wait 4 seconds and the VCR Plus+ system menu will appear.

IMPORTANT

If you have already programmed 8 recording events, Program memory is full will appear on your screen for 3 seconds, and then the Recap screen will appear. Use CANCEL to erase an entry before you can add another one.

- 4 VCR Plus+ system menu appears. See page 33 to learn how to program with VCR Plus+ system. To pass this screen, press ENTER.

- 5 Program to record menu appears. Channel will flash. Press the ADJUST buttons to choose the channel you would like to record. Press ENTER.
 - Select External L1 if you connect an integrated HDTV or an IEEE 1394-equipped HDTV receiver to the rear panel.
 - Select External L2 if you connect an integrated HDTV or an IEEE 1394-equipped HDTV receiver to the front panel.

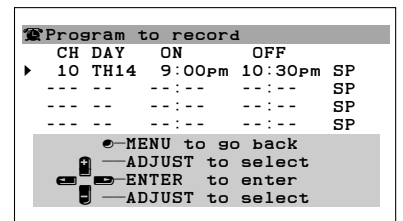
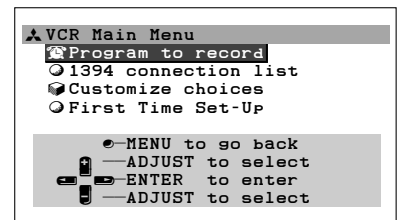

Recap screen

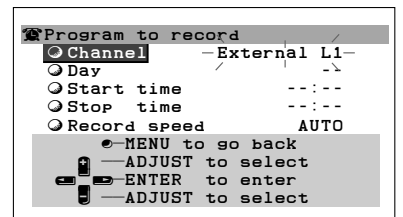
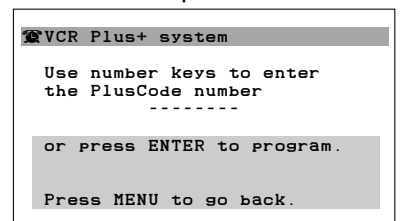

Timer Recording

- 6 Day will flash. Press the ADJUST buttons to choose the day on which you want to record; for example, Monday the 11th. Your choices are:
 - a single day up to one month away.
 - every day from Monday through Friday; for example, to tape a soap opera. To program, press the ADJUST buttons until Monday-Friday appears.
 - the same day every week; for example, to tape your favorite weekly sitcom. To program, press the ADJUST buttons until Every and the desired day of the week appears. Press ENTER once you have made your choice.
- 7 The hour numbers of the start time will flash. Press the ADJUST buttons to set the hour when recording is to start. Press ENTER.
- 8 The minute numbers of the start time will flash. Press the ADJUST buttons to set the minutes when recording is to start. Press ENTER.
- 9 Set the stop time the same way as the start time, using steps 7 and 8.
- 10 Press the ADJUST buttons to set the recording speed: SP = standard play; EP = extended play; AUTO = auto. **Auto speed programming** is discussed on page 35. Press ENTER.

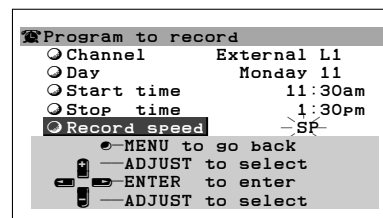
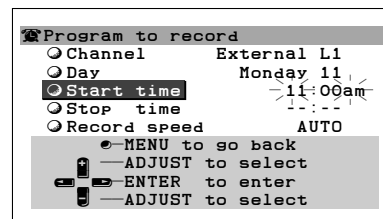
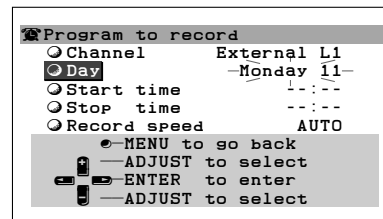

IMPORTANT

If you press ENTER when you set the timer recording incompletely, Current Program is not completed will appear on your screen.

If two programmed recording times overlap, VCR is already programmed for that time will display on your screen for about 3 seconds, and then the Recap screen will appear. The program you have just set will be highlighted in magenta color and flash for 3 seconds. The start and stop time of the overlapped program will be highlighted in cyan color. You will need to erase one of them.

- 11 The programmed memory will appear on the Recap screen.
- 12 To program additional recording times, select an empty program line by pressing ADJUST buttons. Press ENTER. The VCR Plus+ system menu will appear. Continue the programming procedure from step 4.
- 13 When you are finished with all programming, check the following:
 - Leave an integrated HDTV or an IEEE 1394-equipped HDTV receiver turned ON.
 - Turn the VCR power OFF and make sure the programmed recording light is lit.

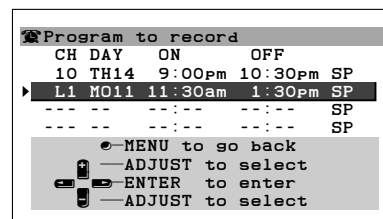

Recap screen

IMPORTANT

While the VCR is recording a digital broadcast, please do not change the channel on an integrated HDTV or an IEEE 1394-equipped HDTV receiver.

The menu or the program list of an integrated HDTV or an IEEE 1394-equipped HDTV will be recorded if it is displayed during recording.

If you record a digital broadcast in VHS format, the picture quality will not be as clear as that of the original digital broadcast.

If you record a copy protected digital program, the copy protect data will also be recorded.

Timer Recording

Conventional VCR Timer Recording

- 1 Load a tape with its erasure prevention tab intact into the VCR.
- 2 Press MENU. VCR Main Menu appears on your screen. Use the ADJUST buttons to select Program to record. Press ENTER.

If there is at least one programmed recording already entered, you will see the Recap screen. Wait 4 seconds and the VCR Plus+ system menu will appear.

IMPORTANT

If you have already programmed 8 recording events, Program memory is full will appear on your screen for 3 seconds and then the Recap screen will appear. Use CANCEL to erase an entry before you can add another one.

- 3 VCR Plus+ system menu appears. See page 33 to learn how to program with VCR Plus+ system. To pass this screen, press ENTER.

- 4 Program to record menu appears. Press the ADJUST buttons to choose the channel you would like to record; for example, channel 2. Press ENTER.
 - If you are using a **cable box**, enter the channel number on which the cable box sends a signal to your VCR (usually channel 3 or 4).
 - To record from an **external source**, press INPUT or press the ADJUST buttons to:
 - Select External L1 for a source connected to the rear panel.
 - Select External L2 for a source connected to the front panel.

- 5 Day will flash. Press the ADJUST buttons to choose the day on which you want to record; for example, Monday the 11th. Your choices are:
 - a single day up to one month away.
 - every day from Monday through Friday; for example, to tape a soap opera. To program, press the ADJUST buttons until Monday-Friday appears.
 - the same day every week; for example, to tape your favorite weekly sitcom. To program, press the ADJUST buttons until Every and the desired day of the week appears.

Press ENTER once you have made your choice.

- 6 The hour numbers of the start time will flash. Press the ADJUST buttons to set the hour when recording is to start. Press ENTER.
- 7 The minute numbers of the start time will flash. Press the ADJUST buttons to set the minutes when recording is to start. Press ENTER.
- 8 Set the stop time the same way as the start time, using steps 6 and 7.

- 9 Press the ADJUST buttons to set the recording speed: SP = standard play; EP = extended play; AUTO = auto. **Auto speed programming** is discussed on page 35. Press ENTER.

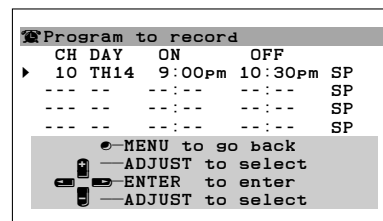
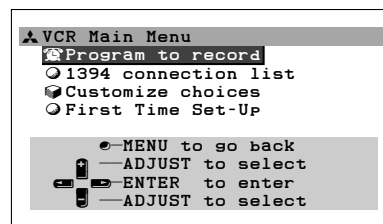

Recap screen

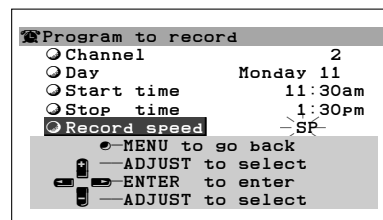
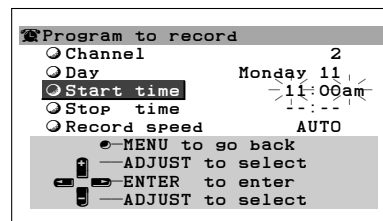
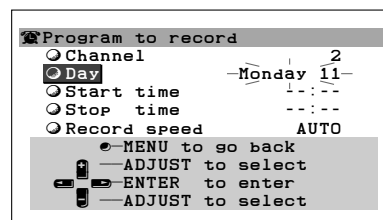
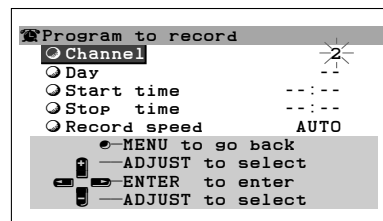
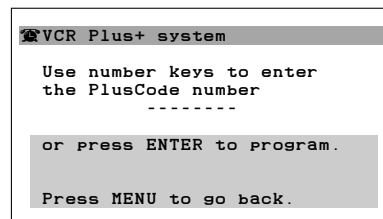

Timer Recording

IMPORTANT

If you press ENTER when you set the timer recording incompletely, Current Program is not completed will appear on your screen.

If two programmed recording times overlap, VCR is already programmed for that time will display on your screen for about 3 seconds, and then the Recap screen will appear. The program you have just set will be highlighted in magenta color and flash for 3 seconds. The start and stop time of the overlapped program will be highlighted in cyan color. You will need to erase one of them.

- 10 The programmed memory will appear on the Recap screen.
- 11 To program additional recording times, select an empty program line by pressing ADJUST buttons. Press ENTER. The VCR Plus+ system menu will appear. Continue the programming procedure from step 3.
- 12 When you are finished entering the programs you wish to record, check the following:
 - If you have a cable box, leave the box tuned to the station you wish to record.
 - Turn the VCR power OFF and make sure the programmed recording light is lit.

IMPORTANT

When programmed recordings of 4 and under are entered, only 4 of the 8 program lines appear on the Recap screen at any one time. To see additional program lines, press the ADJUST buttons to scroll the lines on the screen.

Cancelling a Recording in Progress

There are two ways to cancel a recording in progress:

Press STOP. The recording stops, but the program is not cancelled. Therefore, if you press REC, the recording will start again.

Press POWER on the front panel. The recording stops and the program is cancelled.

Changing while Programming

To change one of your settings (such as start time) while you are programming:

Press ENTER to move forward through the program list.

Press CANCEL to move backward.

Then use the ADJUST buttons to change the setting.

You will cancel the entire program if you press CANCEL while the channel number is flashing.

Recap screen

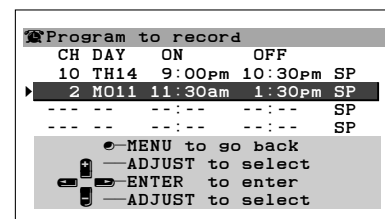

Programming not cancelled

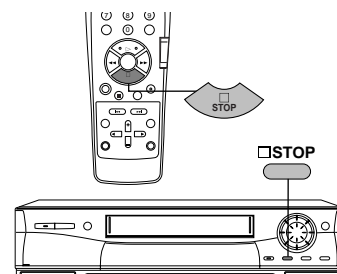

Programming cancelled

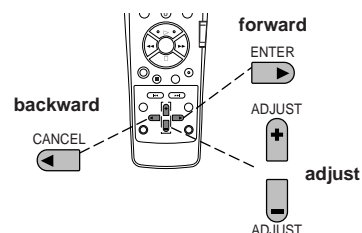

Timer Recording

VCR Plus+® System Programming

The VCR Plus+ system allows you to program your VCR to record by simply entering a PlusCode programming number. You can find this number in *TV Guide* or possibly your local TV listings.

- 1 Load a tape with its erasure prevention tab intact into the VCR.
- 2 Press MENU. VCR Main Menu appears on your screen. Use the ADJUST buttons to select Program to record. Press ENTER.

IMPORTANT

If the VCR memory is full, Program memory is full will appear for 3 seconds, and then the Recap screen will appear. Use CANCEL to erase an entry before you can add another one.

If there is at least one programmed recording already entered, the Recap screen will appear. Wait 4 seconds, and the VCR Plus+ system menu will appear.

- 3 VCR Plus+ system menu will appear. Use the number buttons on the remote control to enter the PlusCode number for the television show you want to record. For example, if the PlusCode number for the program you want to record is 5678, simply enter 5-6-7-8. See your local newspaper or *TV Guide* for PlusCode numbers.
- 4 If you enter a number incorrectly, press CANCEL. When you have finished entering the PlusCode number, press ENTER.

IMPORTANT

If the code number you entered is wrong, The PlusCode number is not valid will display on the screen for 3 seconds and then the VCR Plus+ system menu will reappear.

- 5 Use the ADJUST buttons to select whether you want to record your program once, daily, or weekly.
 - **Once** will record a program one time.
 - **Daily** will record the same channel at the same time, Monday through Friday.
 - **Weekly** will record the same channel at the same time, on the same day each week.

After you have made your choice, press ENTER.

IMPORTANT

If two programmed recording times overlap, VCR is already programmed for that time will display on the screen. You will need to erase the previous program before you can enter the new one.

- 6 Recap screen will appear. The program you have chosen to record will be highlighted.

The channel number will appear in white color. Make sure that the correct channel number is shown on the screen. If the displayed number is not correct, press INPUT to make the number flash, then press the ADJUST buttons to correct the channel number. Press the ENTER to complete.

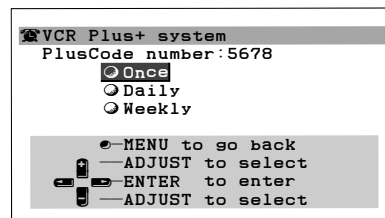
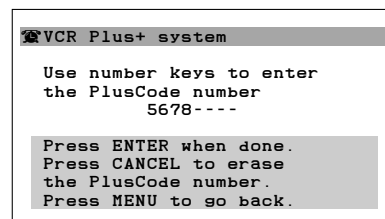
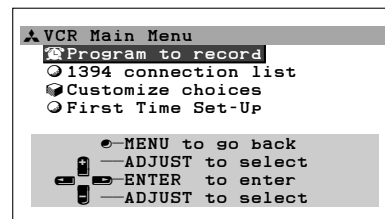

Recap screen

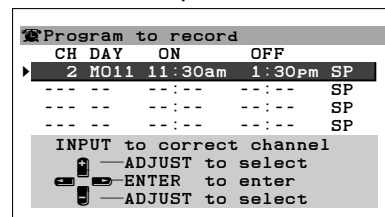

Timer Recording

- 7 If you wish to change the record speed, press ENTER repeatedly until the record speed is flashing. Change the recording speed by pressing the ADJUST buttons. Press ENTER.
- 8 To program additional recording times, select an empty program line by pressing the ADJUST buttons. Press ENTER. You will return to the VCR Plus+ system menu. Continue the VCR Plus+ system programming procedure from step 3.
- 9 When you are finished with all programming, check the following:
 - If you have a cable box, leave the box tuned to the station you wish to record.
 - Turn the VCR power OFF and make sure the programmed recording light is lit.

If you want to stop the programmed recording after it starts, press POWER on the front panel.

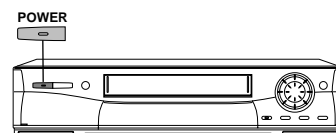
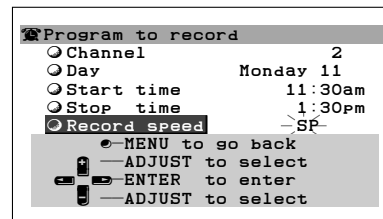

Quick Program

Quick Program is an exclusive Mitsubishi feature that simplifies the process of programming your VCR to record. When you press QUICK PROGRAM/VCR Plus+ on the remote control, you will immediately see the VCR Plus+ system menu and can begin programming right away.

You can use this feature even when the VCR is stopped, playing, fast forwarding, rewinding, or off (Quick program does not work during recording.).

- 1 Press QUICK PROGRAM/VCR Plus+ on the remote control. If the VCR is off, it will turn on. After tuning your TV to the correct channel or input, VCR Plus+ system menu will appear.

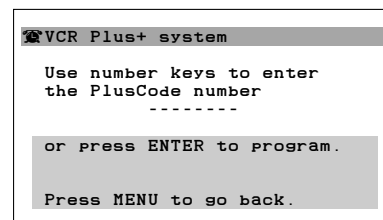
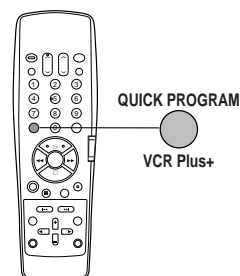

Recap screen

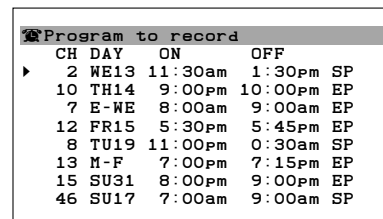

IMPORTANT

If the VCR memory is full, Program memory is full will appear for 3 seconds and then the Recap screen will appear. Use CANCEL to erase an entry before you can add another one.

- 2 Complete steps 3 through 10 in **Conventional VCR timer recording**. (See page 31.)

When you have finished, press QUICK PROGRAM/VCR Plus+ again.

If the VCR is stopped, it will turn off and be ready to record your program at a later time.

If the VCR is playing, fast forwarding or rewinding, the menus will turn off, but the VCR power will remain on.

- 3 When you are finished with entering the programs you wish to record, check the following:
 - If you have a cable box, leave the box tuned to the station you wish to record.
 - Make sure the VCR is turned OFF and the programmed recording light is lit before the recording time.

IMPORTANT

If you press QUICK PROGRAM/VCR Plus+, but the clock is not set, Set the clock menu will appear. Set the clock manually.

Timer Recording

Timer Recording Hints



To use the VCR before timer recording begins, press **POWER** on the remote once. This turns the programmed recording light off and the VCR on.

If you use **POWER** on the front panel for this purpose, press it twice. Pressing it once turns off the programmed recording light; pressing it again turns the VCR on.



When you are finished using the VCR, turn the VCR power off again. Make sure the programmed recording light is back on.

After a program has been recorded, the VCR memory of that program is cleared (unless you have scheduled the VCR to record the program every day or every week).

If there is already a program in the VCR's memory, you will see the Recap screen when you bring up the menus for programming to record (unless you are programming with the **QUICK PROGRAM/VCR Plus+**). If the VCR's memory is full, Program memory is full will appear on the screen. If so, you must erase a program before you can enter a new one.

If a tape runs out during timer recording, the VCR ejects the tape and the programmed recording light () and the tape status symbol () will flash. Load a new tape and press **REC**. Recording will resume.

The programmed recording will be cancelled unless you turn the VCR off before the recording starts. Do not use an integrated HDTV or an IEEE 1394-equipped HDTV receiver to turn on or function the VCR while the VCR is in stand-by mode for the timer recording.

If you forget to load a tape, the programmed recording light () and the tape status symbol () will flash when you turn the VCR power off. (A tape without an erasure tab will be ejected. To correct this, load a tape with its erasure tab intact, and turn off the VCR.)

Do not overlap the recording times you enter into the VCR. If you set two analog programmed recording times to overlap, VCR is already programmed for that time will appear on your screen. When you set the analog and the D-VHS timer recording times overlap, these timer recordings may not be recorded correctly.

Remember that the VCR will record over the next section of tape. If you want to save a tape, remove it and instead use a different tape for a new recording.

Your VCR will not record over a tape that has the erasure prevention tab removed. All rental movies have this tab removed, so they are safe from being accidentally erased.

Auto Speed Programming

Use auto speed programming if you want to record as much of the program as possible in standard play (SP) speed, but you want the VCR to automatically switch to extended play (EP) if there is not enough tape left.

Auto speed programming is only available for one program. In the first slot, the recording speed default is **AUTO**.

Make sure that the Tape video function matches the length of tape you are using. See **Selecting and adjusting the audio and video functions** on page 27.

At the point where the recording mode changes from standard play (SP) to extended play (EP), some noise may be in the picture or sound when playing the tape.

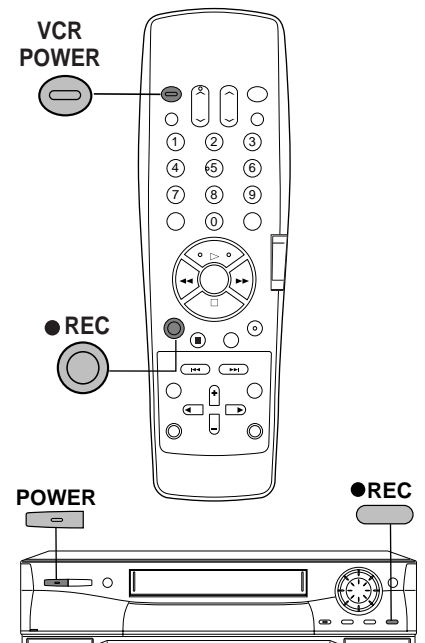

Timer Recording

Program Caution

If your VCR is set to record in VHS format, but the power is still ON within 3 minutes before timer recording starts, this screen will appear to remind you to turn off the VCR.

If the VCR is still turned on 12 seconds before the start time of the recording, that timer recording will be cancelled.

program caution

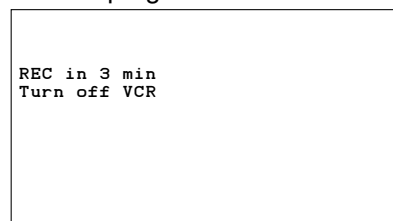

TV Programs that End on the Day After

If you want to start the recording at 11:00 PM and end it at 2:00 AM the next day, simply set the start time to 11:00 PM on the recording start day and the end time to 2:00 AM. There is no need to change the day of the week.

Program Skip Using Menus

Sometimes you may want to skip one day of a timer recording but do not want to erase it. Program skip will prevent the recording, for that day only, of a program you have scheduled to record every day or every week.

- 1 Press MENU on the remote control. Your VCR will turn on and VCR Main Menu will appear. Press the ADJUST buttons to select Program to record. Press ENTER.
- 2 Recap screen will display for 4 seconds. While this screen is displayed, press the ADJUST buttons to place the cursor arrow next to the program you wish to skip.
- 3 Press STOP. The cursor arrow will change to a .
- 4 Press MENU twice to turn off the menus.

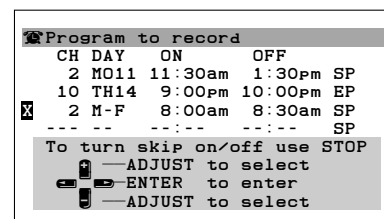
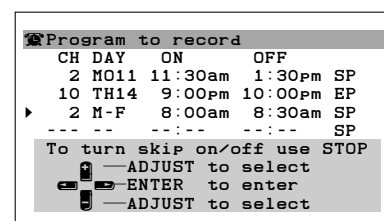

To resume recording every day or every week, change the to the cursor arrow by following steps 1 to 4 again.

Program Skip Using the POWER Button

If you have entered only one program into your VCR's memory, you can skip the program without going into the VCR's menus. Simply press POWER on the front panel once. The programmed recording light will turn off and the program will be skipped. If you decide not to skip the program, press POWER on the front panel twice; the programmed recording light will light up again.

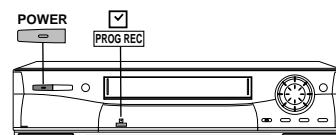

Changing Timer Recording Settings

- 1 Press MENU on the remote control. Your VCR will turn on and VCR Main Menu will appear. Press the ADJUST buttons to select Program to record. Press ENTER.
- 2 Recap screen will display for 4 seconds. While this screen is displayed, press the ADJUST buttons to place the cursor arrow next to the program you wish to change. Press ENTER. You will see the Program to record setting menu.
- 3 Press ENTER repeatedly to select the item you wish to change. Press the ADJUST buttons to change it. Then press ENTER repeatedly to return the altered program to the Recap screen.
- 4 Press MENU twice to turn off the menus. Then press POWER to turn off the VCR. Make sure the programmed recording light is on.

Recap screen

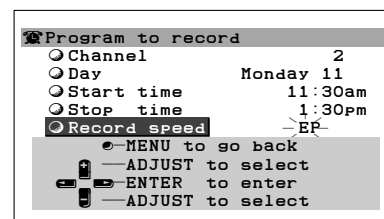
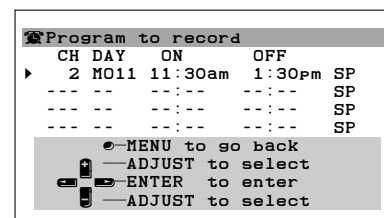

Timer Recording

Canceling a Timer Recording before the Recording Starts

- 1 Press MENU on the remote control. Your VCR will turn on and VCR Main Menu will appear on your screen. Press the ADJUST buttons on the remote control to select Program to record. Press ENTER.
- 2 Recap screen will display for 4 seconds. While this screen is displayed, press the ADJUST buttons to place the cursor next to the program you wish to cancel.
- 3 Press CANCEL. The program is erased.
- 4 Press MENU twice to turn off the menus.

Recap screen

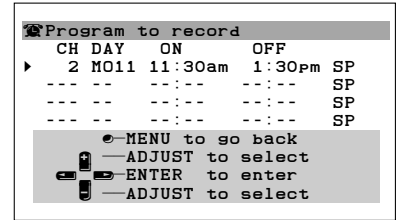

TIMER RESET

You can use TIMER RESET on the rear panel to erase both the clock and all timer recordings.

To use TIMER RESET, press it with a pencil or a ball point pen. The power will turn off and the clock will be cleared. All timer recordings are erased.

If you have set the Auto clock set setting of the Set the clock menu to ON, the auto clock function will automatically set the clock again.

Memory Backup

If the VCR is without power for 30 minutes or less, it will retain the clock and the programmed settings. The VCR must have been plugged in for at least an hour beforehand to charge this backup. If the power is lost for more than 30 minutes, the time and the programmed settings will be lost.

If you have set the Auto clock set setting of the Set the clock menu to ON, the auto clock function will automatically set the clock again when power is restored.

VCR Rear Panel

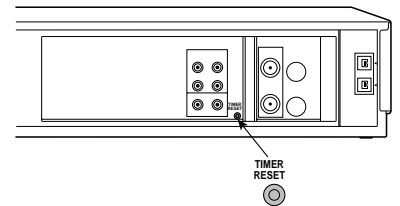

Editing Features

Copying a Tape from D-VHS to D-VHS

When you connect a D-VHS VCR equipped with IEEE 1394 INTERFACE terminal to the HS-HD1100U with an IEEE 1394 cable, you can copy a tape from D-VHS format to D-VHS. You cannot edit the tape while copying from D-VHS to D-VHS.

- 1 Connect an IEEE 1394 cable to IEEE 1394 INTERFACE on the playback VCR and to IEEE 1394 INTERFACE on the HS-HD1100U. You can use either of the two IEEE 1394 INTERFACE terminals.

IMPORTANT

Do not pull out an IEEE 1394 cable during copying the tape.

You cannot copy a tape in D-VHS format from digital video equipment (for example, digital video camera) even if it is connected with an IEEE 1394 cable.

- 2 Set the recording VCR to be able to control the playback VCR.
To do this, when you use HS-HD1100U as a recording VCR, press IEEE 1394 INPUT on the remote control to display d1 to d5 on the front panel which will correspond to the D-VHS VCR used as a playback VCR. If you use this VCR as a playback VCR and the other VCR as a recording VCR, refer to the recording VCR owner's guide for this procedure.
- 3 Put a D-VHS tape with the erasure prevention tab intact to the recording VCR.

- 4 When you are using the HS-HD1100U as a recording VCR, make sure that the D-VHS button on the front panel is lit. If it is not, press the button to light it up.
- 5 Put the tape you want to copy into the playback VCR and find the cue point. Press STOP if the picture starts playing.

IMPORTANT

As it will take a few seconds to automatically select the recording mode, stop the tape slightly before the point you want to start copying.

- 6 On the playback VCR, press PLAY, then PAUSE.
- 7 On the recording VCR, press REC, then PAUSE.
- 8 Press the PAUSE buttons on both VCRs at the same time to begin copying the tape.
- 9 When finished, press STOP on both VCRs.

IMPORTANT

The programs prohibited from copying or the programs with copy restriction cannot be copied correctly. When you use the HS-HD1100U as a recording VCR and copy such programs, no COPY appears on the front panel display.

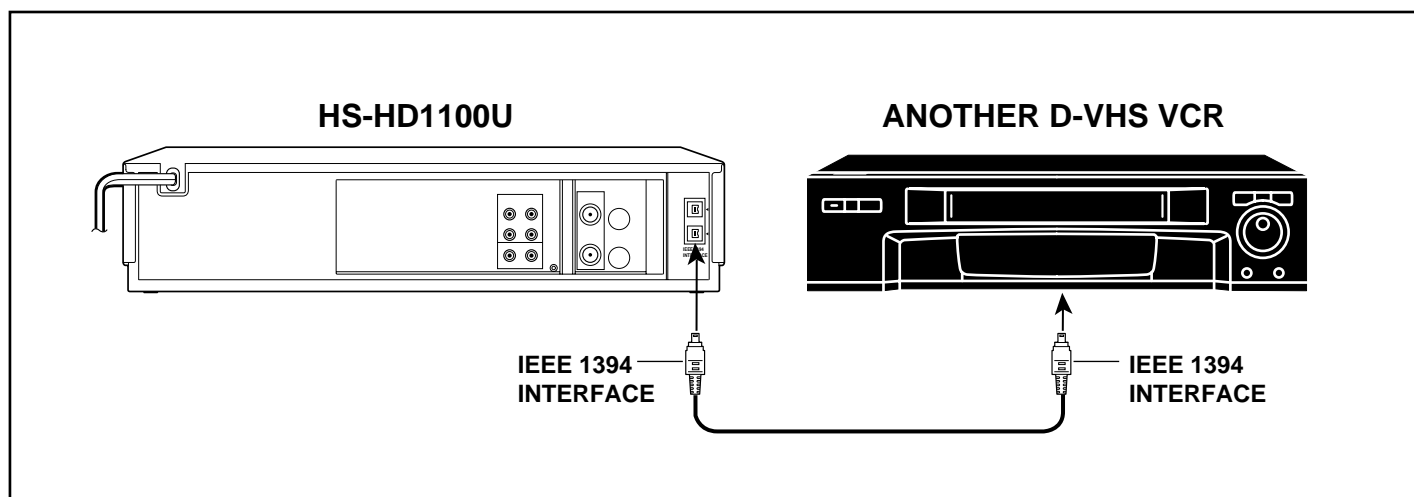

Editing Features

Copying a Tape from D-VHS to Analog

To copy a tape from D-VHS to analog format, use the HS-HD1100U as a playback VCR and connect to an integrated HDTV or an IEEE 1394-equipped HDTV receiver with an IEEE 1394 cable. And then connect an integrated HDTV or an IEEE 1394-equipped HDTV receiver to the recording VCR with an S-video/video and audio cable. The digital signal which is played back on HS-HD1100U will be changed to analog signal by an integrated HDTV or an IEEE 1394-equipped HDTV receiver, and this analog signal will be sent to the recording VCR to be recorded.

- 1 Connect an IEEE 1394 cable to IEEE 1394 INTERFACE on an integrated HDTV or an IEEE 1394-equipped HDTV receiver and to IEEE 1394 INTERFACE on the HS-HD1100U. You can use either of the two IEEE 1394 INTERFACE terminals.
 - 2 Connect the audio cable to AUDIO OUT L and R on an integrated HDTV or an IEEE 1394-equipped HDTV receiver and to AUDIO IN L and R on the recording VCR.
 - 3 If the recording VCR is S-VHS, connect an S-video cable to S-VIDEO OUT on an integrated HDTV or an IEEE 1394-equipped HDTV receiver and to the recording VCR.
- 5 Put a blank tape into the recording VCR. If you want to record in S-VHS, be sure to use an S-VHS tape.
 - 6 Put the tape you want to copy into the HS-HD1100U and find the cue point. Press STOP if the picture starts playing.
 - 7 On the recording VCR, press REC, then PAUSE.
 - 8 On the HS-HD1100U, press PLAY, then PAUSE.
 - 9 Press the PAUSE buttons on both VCRs at the same time to begin copying the tape.
 - 10 When finished, press STOP on both VCRs.

If the recording VCR is standard VHS, connect a video cable to VIDEO OUT on an integrated HDTV or an IEEE 1394-equipped HDTV receiver and to the VIDEO IN on the recording VCR.

- 4 Select the external input of the recording VCR.

IMPORTANT

The picture quality of the copied program will not be as clear as that of the original digital broadcast.

Digital programs with copy restriction or programs prohibited from copying cannot be copied.

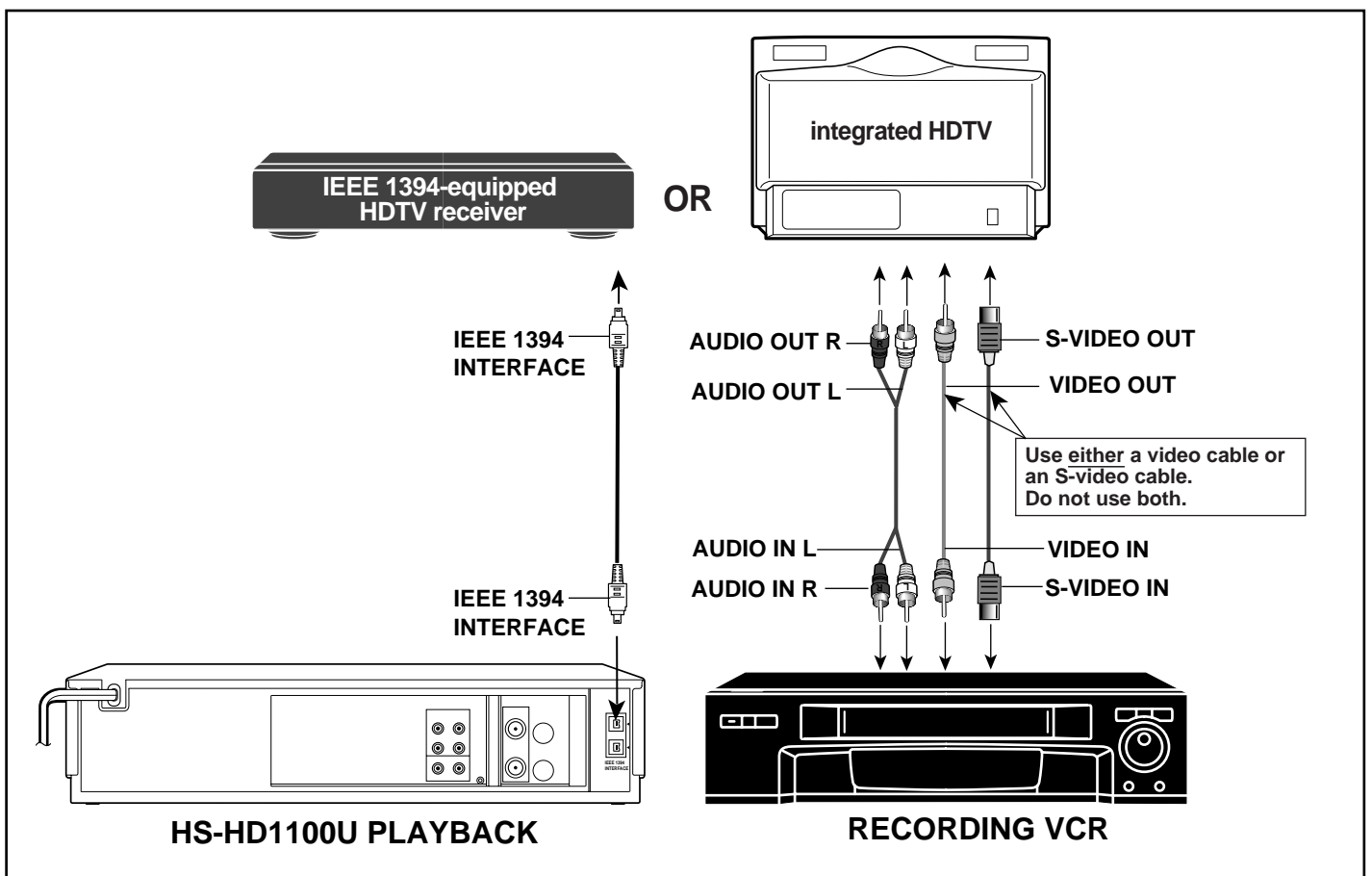

Editing Features

Copying a Tape from Analog to Analog

There are two basic ways to make a copy of a tape from analog to analog. One way is to use the HS-HD1100U to record and another VCR for playback. The other way is to use another VCR to record and use the HS-HD1100U for playback.

Regardless of which method you may choose, you will need one RCA audio cable and video cable to connect the two VCRs. If you do not have these cables, they are available at your local electronics dealer.

Using the HS-HD1100U to Record from Another VCR

- 1 Connect the audio cable to AUDIO OUT L and R on the playback VCR and to AUDIO IN L and R on the HS-HD1100U. If the playback VCR is mono, use only the AUDIO IN L on the HS-HD1100U.
- 2 Connect a video cable to VIDEO OUT on the playback VCR and to the VIDEO IN on the HS-HD1100U.
- 3 If the playback VCR is Hi-Fi, set the audio monitor to **Stereo**.
- 4 Use INPUT to set the HS-HD1100U to **External L1** (L1) if you used the HS-HD1100U rear panel jacks, or **External L2** (L2) if you used the HS-HD1100U front panel jacks.
- 5 Put a blank tape into the HS-HD1100U.
- 6 Put the tape you want to copy into the playback VCR and find the cue point. Press STOP if the picture starts playing.
- 7 On the HS-HD1100U, press REC, then PAUSE.
- 8 On the playback VCR, press PLAY, then PAUSE.
- 9 Press the PAUSE buttons on both VCRs at the same time to begin copying the tape.
- 10 When finished, press STOP on both VCRs.

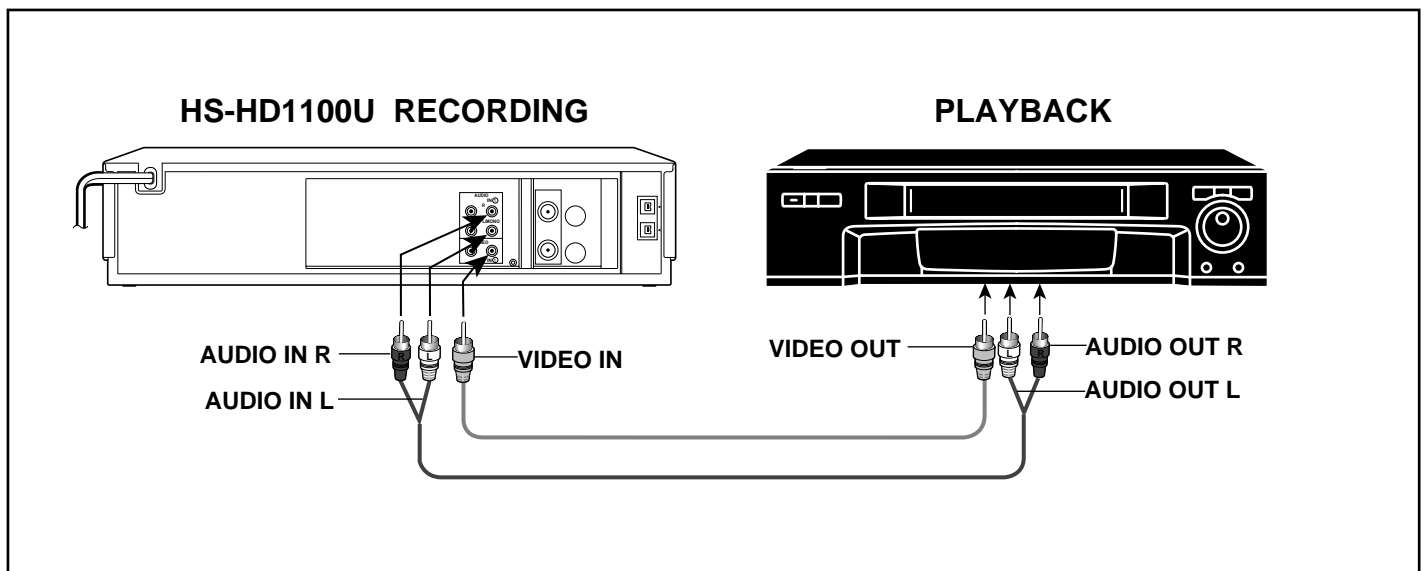

Editing Features

Using the HS-HD1100U to Playback to Another VCR

- 1 Connect one stereo audio cable to AUDIO IN L and R on the recording VCR, and to AUDIO OUT L and R on the HS-HD1100U.
- 2 Connect a yellow video cable to VIDEO IN on the recording VCR and to VIDEO OUT on the HS-HD1100U.
- 3 Set the audio monitor on the HS-HD1100U to **Stereo**.
If the other VCR is mono VCR, set the audio monitor on the HS-HD1100U to **Mono**. See **Selecting and adjusting the audio and video functions** on page 27.
- 4 Set the input of the recording VCR to **External**.
- 5 Put a blank tape into the recording VCR.
- 6 Put the tape you want to copy into the HS-HD1100U and find the cue point.
- 7 On the recording VCR, press REC, then PAUSE.
- 8 On the HS-HD1100U, press PLAY, then PAUSE.
- 9 Press the PAUSE buttons on both VCRs at the same time to begin copying the tape.
- 10 Press STOP on both VCRs when you are finished.

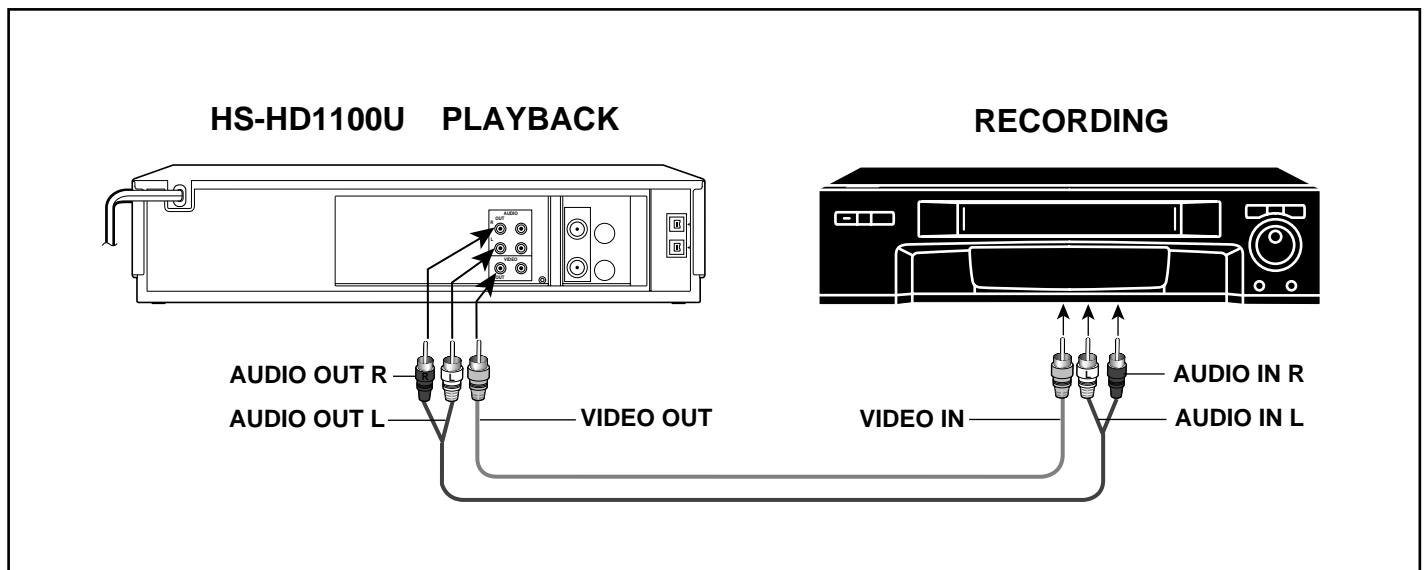

Advanced Features

Advanced Playback Controls (for analog playback only)

Special Effects

You can use the shuttle ring and the jog dial on the front panel, or **▶▶|** and **|◀◀** on the remote to control the playback speed of the tape.

Change the playback speed while tape is paused

- 1 While the VCR is playing a tape, press PAUSE to freeze the picture.
- 2 Turn the shuttle ring on the front panel and hold it to play the tape at a particular speed (see diagram). If you release the ring, it will come back to the center position, and the still (PAUSE) mode will resume.
- 3 To resume normal playback, press PLAY.

Change the playback speed while tape is playing

You can change the playback speed with the shuttle ring without entering the PAUSE mode. To do this, turn the shuttle ring and hold it to play the tape at a particular speed (see the diagram). If you release the ring, it will come back to the center position and normal playback will resume.

You can also change the playback speed while the tape is playing with the **▶▶|** and **|◀◀** on the remote control.

- 1 While the VCR is playing a tape, press **▶▶|** or **|◀◀** on the remote control. Each press of **▶▶|** changes the playback speed by one step in the forward direction. Each press of **|◀◀** changes the speed by one step in the reverse direction. (See the chart below.)
- 2 To resume normal playback, press PLAY.

After about 5 minutes in the still or slow-motion mode, the VCR will automatically stop to avoid damage to the tape. The picture may vibrate vertically when you pause the VCR's picture.

Press **|◀◀** on the remote control

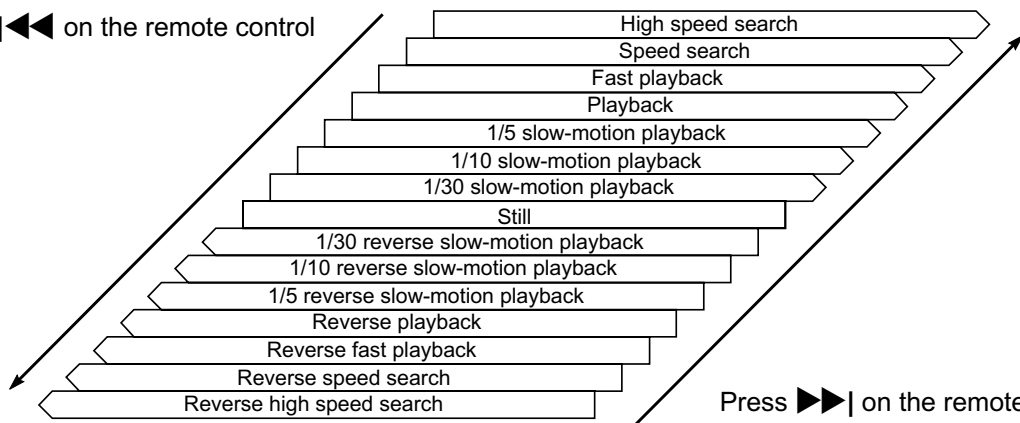

Press **▶▶|** on the remote control

Advance tape frame by frame

- 1 While the VCR is playing a tape, press PAUSE to freeze the picture.
- 2 Turn the jog dial on the front panel clockwise or press ADJUST + on the remote to advance the tape forward. Turn the jog dial counter-clockwise or press ADJUST - to reverse the tape. The faster you turn the dial or press the ADJUST button, the faster the tape will move.
- 3 To resume normal playback, press PLAY.

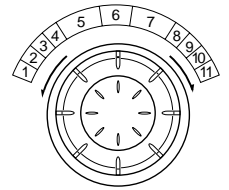

- 1 Reverse high speed search
- 2 Reverse speed search
- 3 Reverse fast playback
- 4 Reverse playback
- 5 Reverse slow-motion playback
- 6 Still
- 7 Slow-motion playback
- 8 Playback
- 9 Fast playback
- 10 Forward speed search
- 11 Forward high speed search

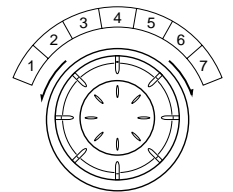

- 1 Reverse high speed search
- 2 Reverse speed search
- 3 Reverse fast playback
- 4 Playback
- 5 Fast playback
- 6 Forward speed search
- 7 Forward high speed search

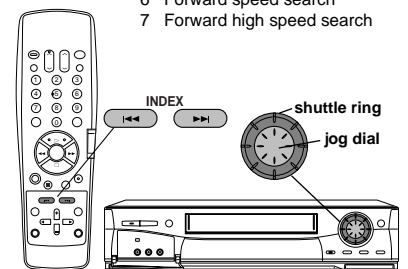

Advanced Features

Adjusting the Tracking

automatic tracking

Your VCR automatically adjusts the tape to give you the best quality picture. When you start playback of a newly inserted tape, the DIGITAL TRACKING light (D) will flash, showing that the VCR is adjusting the picture. When the VCR has finished adjusting the picture, the DIGITAL TRACKING light will shine steadily.

A certain amount of “noise” in the picture or sound is normal while the VCR is tracking a tape.

manual tracking

From time to time, you might play a tape that has excess noise in the picture, often looking like vibration or interference at the top or bottom of the screen, or during D-VHS playback, a mosaic noise, still or black picture may appear. To correct the picture, you have to manually track the tape.

- 1 While the tape is playing, press and hold SP/EP and turn the front panel jog dial until the picture is clear of excess noise.
- 2 To continue automatic tracking, press SP/EP again. Automatic tracking will also resume when you eject the tape.

slow tracking (for analog playback only)

Slow tracking is used to adjust the playback quality during slow motion playback and still frame. You can only use slow tracking if your tape was recorded in extended play (EP) speed. To adjust the slow tracking, put a tape into slow motion, then press and hold SP/EP and turn the front panel jog dial until the best picture is obtained.

Time Counter

Your VCR has a time counter that shows the amount of time the tape has run in hours, minutes, and seconds. This counter is useful when you want to find specific points on a tape. The counter will not work when playing blank tapes or on blank sections of tape, or when the VCR's power is off.

setting the counter

To set the counter to “0H00M00S,” press CANCEL on the remote control.

You cannot reset the counter if you are using the VCR's menus.

The counter will reset to “- - H - - M - - S” when you eject a tape. When you load a tape again, the counter will display “0H00M00S.”

Searching Techniques

Your VCR lets you search through a tape in a number of ways. These include:

- Quick search (CM skip)** -- 30 second intervals
- Speed search** -- visually search
- Counter zero stop** -- direct to start of recording
- Index search** -- find specific index points
- Search to blank** -- find the beginning of the blank section

When you record a digital program, there is a chance that it was broadcast as a non-standard digital signal. This means that while this D-VHS VCR can record the program, it may not display a picture when you use the visual search function (i.e. Speed Search). This is not a defect of the D-VHS VCR player.

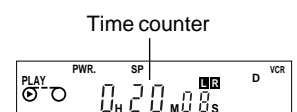
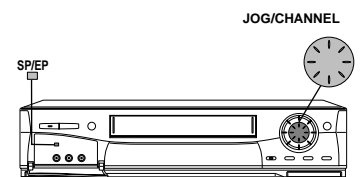
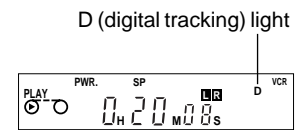

Advanced Features

Quick search (CM skip)

Quick search lets you skip over the tape you are playing in about 30 second intervals. It is designed so that you can quickly speed through any commercials you may have recorded. To do this:

- 1 Make sure that you have set the VCR/TV slide switch on the remote control to the VCR position.
- 2 While playing a tape, choose the desired search time by pressing a number button.

Number button	1	2	3	4	5	6
Search time	30 sec.	1 min.	1 min. 30 sec.	2 min.	2 min. 30 sec.	3 min.

The VCR will speed through the selected length of tape, then resume playback. This screen will show the search time and the gauge. Each mark on the gauge represents 15 seconds. The marks will disappear, one by one, every 15 seconds of the search time. You can select a search time up to 3 minutes.

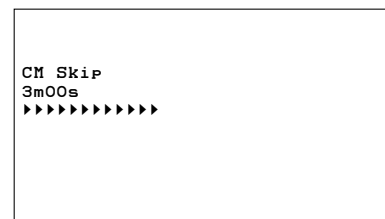

Speed search

Use speed search to visually search through the contents of a videotape.

- 1 While playing a tape, press FF or REW on the remote control. You will see the picture as it fast forwards or rewinds. Noise bars may appear in the pictures.
- 2 When you are playing the tape recorded in analog format, if you press FF or REW and hold it down for about 1 second, the search speed will increase.
- 3 To resume normal playback, press FF or REW again quickly, or press PLAY.

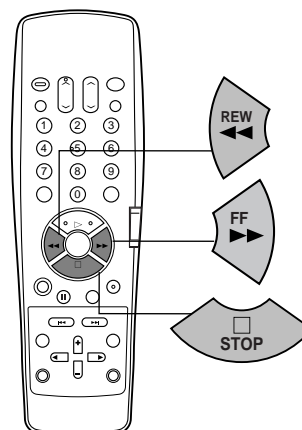

IMPORTANT

The fastest search speed that allows you to see the picture is about 30 times of normal speed. It is normal for the number of noise bars on the screen to increase and roll from top to bottom as the visual search speed increases. Using speed search for long stretches of tape may cause the video heads to become dirty faster.

The fastest way to move through the tape is without a picture, which allows you to search up to 500 times normal speed (for the tape recorded in analog format). To do this, press STOP, then FF or REW. If you press and hold FF or REW for more than 2 seconds, the search speed will slow to 280 times normal speed (for the tape recorded in analog format).

In order to protect your tapes and the VCR heads, the Fast Forwarding/ Rewinding Speed will be slower than 500x under the following conditions:

- 1 Use of tapes shorter in length than T-120 (for example, T-30, T-60, T-90).
- 2 Use of tapes longer in length than T-120 (for example, T-160, T-180, T-210. Also for DF-300, DF360, DF-420, and DF-480).

- 3 Activating fast forwarding or rewinding from the middle of the tape.

Speed search may not work correctly when playing back a tape recorded in both analog and digital format on the same tape.

When you record a digital program, there is a chance that it was broadcast as a non-standard digital signal. This means that while this D-VHS VCR can record the program, it may not display a picture when you use the visual search function (i.e. Speed Search). This is not a defect of the D-VHS VCR player.

The speed search may not work correctly when playing back a program recorded by multi stream recording or depending on the program you have recorded.

Advanced Features

Counter zero stop

Counter zero stop allows you to quickly access the beginning of a recorded or playback section of a tape. The counter zero stop will automatically fast forward or rewind the tape to "0H00M00S" and stop.

- 1 Press CANCEL on the remote control at the point you wish to locate later. The counter will reset to "0H00M00S."
- 2 When you wish to return to the point specified in step 1, press AUDIO/VIDEO on the remote control. The audio and video function menu appears on your screen. Press AUDIO/VIDEO until the Counter zero stop function appears.
- 3 Press ENTER to start the counter zero stop.

The VCR will automatically search to the counter "0H00M00S" and then stop. The VCR may stop slightly before or after the counter "0H00M00S."

Index search

Index search is a way to find specific points on a tape. Before using index search, index marks will be placed at specific places on the tape. Index search is then used to find these marks. Index marks are added automatically whenever your VCR starts a new recording; you can also add index marks manually at any point during recording.

automatic index marks

Whenever recording is begun from STOP mode, an index mark is automatically added to the tape. When recording in VHS format, a message will indicate that the mark is being added.

Index marks are not added when you press PAUSE or REC to begin recording from the record-pause mode.

manual index marks

To add an index mark yourself, press REC on the remote control while a tape is recording.

Index marks must be added at least one minute apart.

- 1 When the tape is stopped, press INDEX ►►I to begin a forward search; press INDEX I◄◄ to search in reverse. The VCR will fast forward or rewind and index search display appears on the TV.

Once the VCR finds an index mark, it will begin playing back the tape from that point.

- 2 You can press INDEX ►►I or INDEX I◄◄ up to 19 times to search for that many index marks. For example, to find the third index mark ahead from the point you are at, press INDEX ►►I three times. The on-screen display will count down the number of marks passed before playback begins.
- 3 To cancel index search, press STOP.

IMPORTANT

Index search may not work correctly if the interval between two index marks is shorter than 5 minutes in HS (high speed) mode, 10 minutes in STD (standard) mode, 5 minutes in SP (standard play) mode or 15 minutes in EP (extended play) mode.

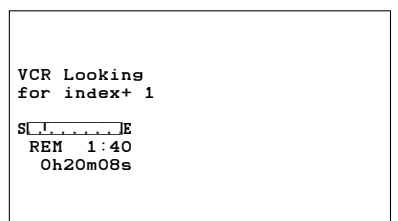
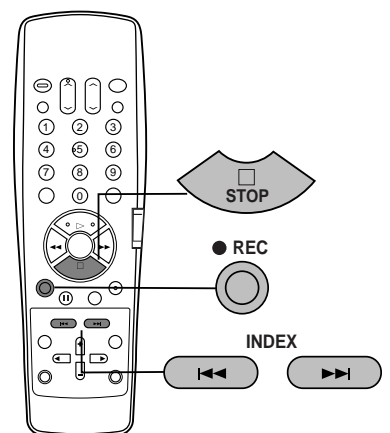
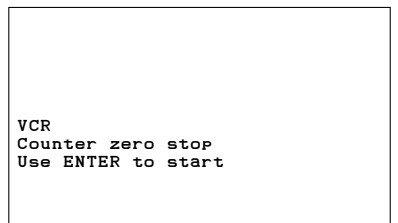

(This screen appears during analog playback only.)

Advanced Features

repeat playback

You can playback a section of tape over and over using repeat playback. The tape will play until the next index mark, rewind to the previous index mark and resume playing. If there is only one index mark on the tape, then the VCR will play or rewind to that mark and resume playback. If there is no index mark, the entire cassette will repeat.

1 Press AUDIO/VIDEO on the remote control to display the audio and video function menu. Press AUDIO/VIDEO until the Repeat play function appears.

2 To start the playback, press ENTER.

When the VCR encounters the next mark or the end of the tape, it will automatically rewind to the previous mark and begin playback again.

The VCR will also search for a blank section of the tape. If the VCR encounters any blank sections longer than 4 seconds in length, the repeat playback will begin.

3 Press STOP to cancel the repeat.

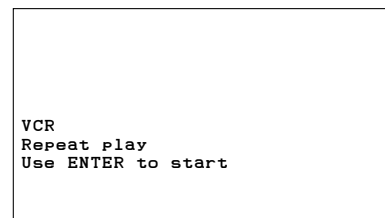

IMPORTANT

For the tape recorded in D-VHS format, repeat playback may not work correctly depending on the recording condition.

Search to blank

This feature allows you to find the end point of the recorded part of the tape. The VCR will stop automatically at the beginning of the blank section of a tape.

1 Press AUDIO/VIDEO on the remote control to display the audio and video function menu. Press AUDIO/VIDEO until the Search to blank function appears.

2 To start the search, press ENTER.

When the VCR encounters the blank section of a tape, it will automatically stop.

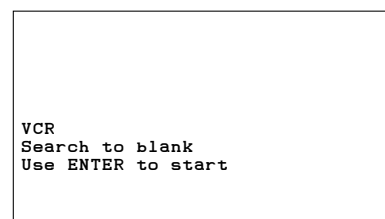

IMPORTANT

This feature may not work if the blank section is 5 minutes or less apart in HS mode, 10 minutes or less in STD mode, 5 minutes or less in SP mode or 15 minutes or less in EP mode.

Displaying the Time Gauge and the Remaining Time

The time gauge is a graphic representation of your position on a video tape. The left side of the gauge is the tape start (S), and the right side is the tape end (E). For a T-120 length tape played at standard (SP) speed, each mark on the gauge represents about 15 minutes. The remaining time display shows the time, in hours and minutes, left until the end of a tape.

the time gauge and the remaining time automatically appear during:

- fast forward and rewind (from a stopped tape)
- counter zero stop
- index searches
- rewinding for repeat playback
- search to blank

Turn off the time gauge and the remaining time by pressing DISPLAY twice.

to make the time gauge and the remaining time appear:

Press DISPLAY once. The time gauge and remaining time appear on the TV screen and the remaining time appears on the front panel display. They disappear after 4 seconds when playing a tape.

To turn off the display, press DISPLAY twice.

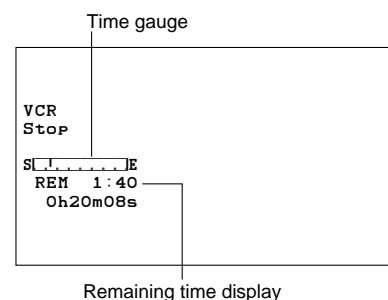

(This screen appears during analog playback only.)

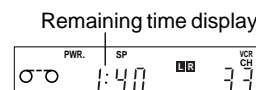

Advanced Features

IMPORTANT

The time gauge and remaining time work by detecting control signals on recorded tapes. Therefore, they do not function while playing blank tapes.

The remaining time display may not show the correct remaining time if the **Tape** or **D-VHS Tape** function is incorrectly set, if you are using speed search, if you are using a special length cassette (such as T-10 length), or if you are using a VHS-C tape with an adapter.

The remaining time display may not work correctly depending on your tape.

Displaying the Current Time

The current time is shown in the front panel display or the TV screen. If you have not set the clock, or if there has been a power failure of longer than 30 minutes, the display will show - : - : -. The current time will be displayed when the VCR is off.

To see the current time when the VCR is on:

- 1 Press DISPLAY twice. The remaining time display will be replaced by the current time.
- 2 To turn off the current time, press DISPLAY again.

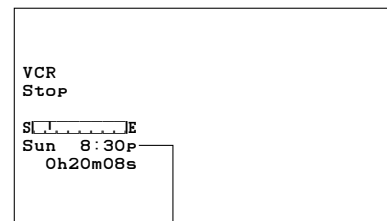

Current time display

(This screen appears during analog playback only.)

Current time display

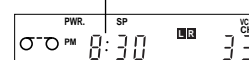

Customize Choices Menu

In the Customize Choices menu, there are 6 options that you can set. For each of the 6 options, start with these 2 steps:

- 1 Press MENU on the remote control. VCR Main Menu appears on your TV.
- 2 Use the ADJUST buttons on the remote to select Customize choices. Press ENTER.

IMPORTANT

Customize choices menu consists of two pages. To display the next page, use the ADJUST buttons to select Go to next page and press ENTER. To go back to the previous page, use the ADJUST buttons to select Back to previous page.

Video mute

When you turn Video Mute ON, any blank section of tape or many stations with a weak signal will be replaced by a blue screen. The sound will also be turned off. When you would like to try to tune in on a weak station, turn Video Mute OFF.

- 3 Complete steps 1 and 2 above. Customize choices menu appears. Use the ADJUST buttons to select Video mute. Press ENTER to set Video Mute to ON or OFF.
- 4 Press MENU twice to exit the menus.

IMPORTANT

Video Mute function may not work properly when you playback a section of a tape where only audio signals are recording.

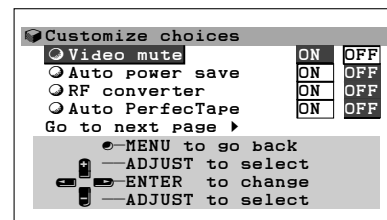
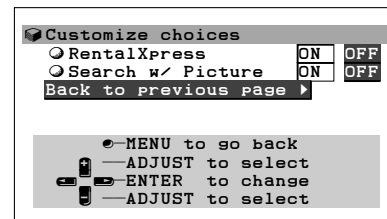
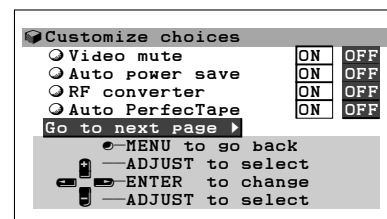
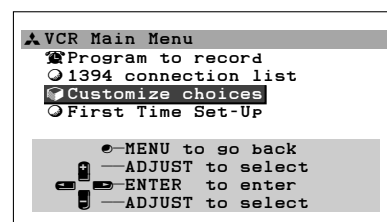

Advanced Features

Auto power save (auto-off)

When the Auto Power Save feature is turned on, the VCR will automatically turn off after remaining idle for 30 minutes. If a control, such as a menu function or channel selection is used or if there is a tape playing or being recorded, the VCR will remain on.

- 3 Complete steps 1 and 2 on the previous page. Customize choices menu appears. Use the ADJUST buttons to select Auto power save. Press ENTER to set to ON.
- 4 Press MENU twice to exit the menus.

IMPORTANT

When viewing analog broadcast stations through the VCR, 3minutes→Power off will appear on the TV screen three minutes before the VCR power turns off. The display will count down the number of minutes until the VCR turns off. If you want to continue using the VCR, press any of the buttons.

RF converter

If your TV has audio and video inputs, turn the RF converter OFF. If your TV does not have audio and video inputs, keep the RF converter set to ON. It is preset by the factory to ON.

- 3 Complete steps 1 and 2 on the previous page. Customize choices menu appears. Use the ADJUST buttons to select RF converter. Press ENTER to select ON or OFF.
- 4 Press MENU twice to exit the menus.

IMPORTANT

If the RF converter is set to ON, you aren't required to press VCR/TV to play a tape or to use VCR menus. The VCR light will automatically light up when you press PLAY or MENU. Be sure to set the TV to the video channel (see page 12).

PerfectTape®

PerfectTape® is an exclusive Mitsubishi feature that tests the quality of video tapes you will record on. After each test, the VCR will adjust its internal circuitry in order to make the best possible recording on your tape.

setting up PerfectTape®

You can set up PerfectTape® to function two ways.

If you want the VCR to automatically test any non-recorded tapes when the tape is loaded, set Auto PerfectTape to ON.

If you do not want the VCR to automatically test tapes, select OFF. PerfectTape® will now function only when you start a test. Any tape with the erasure prevention tab intact can be manually tested.

It will not automatically test recorded tapes – you must choose to test those yourself.

- 3 Complete steps 1 and 2 on the previous page. Customize choices menu appears. Use the ADJUST buttons to select Auto PerfectTape.
- 4 Press ENTER to set Auto PerfectTape to ON or OFF.
- 5 Press MENU twice to exit the menus.

using PerfectTape® automatically

- 1 Load a blank tape into the VCR.

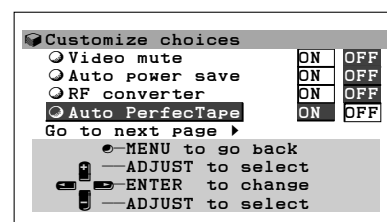
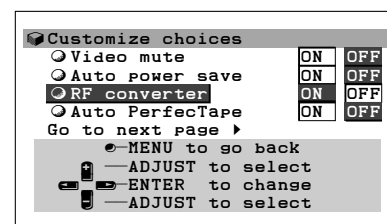
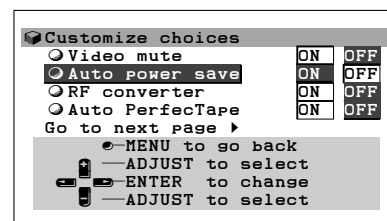

Advanced Features

The VCR will display the testing status screen. When testing, the VCR records for one second, then evaluates the recording it made. The entire test takes about 8 seconds. During this time, the PT light on the front panel will flash. If you wish to cancel the test, press STOP on the remote while the PT light is still flashing.

When the test is done, the VCR will display the rating of your tape for 8 seconds. On the front panel, the PT light will shine steadily, indicating that the VCR has set its internal circuitry to make the best possible recording on this tape.

using PerfectTape® manually

- 1 Load a tape that has its erasure prevention tab intact into the VCR.
- 2 Find a portion of the tape that is OK to record over; this feature will record over one second of your tape.
- 3 Press AUDIO/VIDEO on the remote control. Audio and video function menu appears. Press AUDIO/VIDEO until the PerfectTape function appears.
- 4 Press ENTER on the remote to begin the test. During this time, the PT light on the front panel will flash. To cancel the test, press STOP on the remote while the PT light is still flashing.

When the test is finished, the VCR will display the rating of your tape for 8 seconds. Turn off the display by pressing STOP on the remote control.

If you wish to erase the settings, eject the tape. The settings will also be erased if you press TIMER RESET or if the VCR loses power. After the test is finished, the PerfectTape function will not appear unless the tape is ejected.

RentalXpress

RentalXpress is a feature, when activated, that will automatically rewind the tape to the beginning, eject and power off the VCR, after it has reached the blank section of 30 seconds or longer on any rental tape (or any tape with the erasure prevention tab removed). To activate this feature:

- 3 Complete steps 1 and 2 on page 47. Customize choices menu appears. Use the ADJUST buttons to select Go to next page. Press ENTER.
- 4 Press the ADJUST buttons to select RentalXpress. Press ENTER to select ON or OFF.
- 5 Press MENU twice to exit the menus.

IMPORTANT

While the VCR is rewinding to the beginning of the tape, you cannot use repeat playback, counter zero stop and index search.

Search with Picture

When you set Search w/ Picture setting to ON, it allows you to search (FWD/REW) your D-VHS recording with picture. If you turn this setting OFF, you will not see any picture while "searching." It is preset to ON at the factory.

- 3 Complete steps 1 and 2 on page 47. Customize choices menu appears. Press the ADJUST buttons to select Go to next page. Press ENTER.
- 4 Press the ADJUST buttons to select Search w/ Picture. Press ENTER.
- 5 Press MENU twice to exit the menus.

IMPORTANT

Even if you set Search w/ Picture to ON, there may be instances where there will be a frozen picture or no picture while you search. This is due to the signal that was recorded. This is not a defect of the D-VHS.

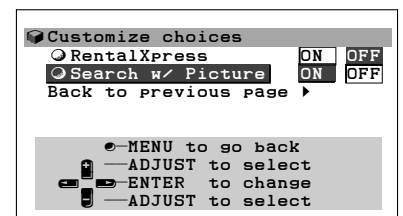
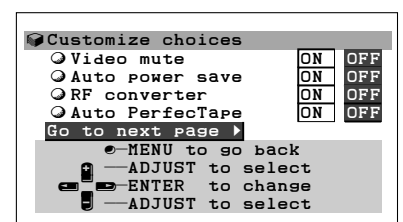
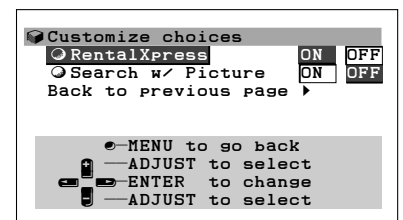
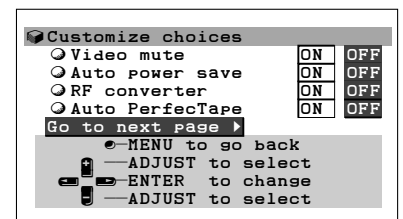
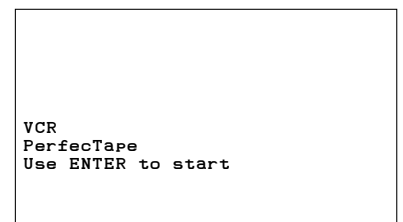
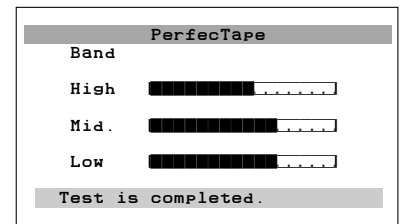

Advanced Features

Advanced Options

Using the remote control to operate your TV

The HS-HD1100U remote control can operate many of the frequently-used functions of your TV. You only need one remote to operate both your VCR and TV.

The HS-HD1100U remote control is pre-set to operate Mitsubishi televisions, but it can also operate TVs from other manufacturers. To set your remote control for your particular brand of television, follow these instructions.

setting up your remote control to operate your TV

- 1 Turn off your TV.
- 2 On the HS-HD1100U remote control, set the VCR/TV slide switch to the TV position.
- 3 While holding in SP/EP, press the code listed that corresponds to the brand of your TV.
- 4 Press TV POWER on the HS-HD1100U remote control. Once your TV has turned on, your remote is set up to operate your brand of TV.

If your TV does not turn on, repeat step 3 using the next code listed for the brand of your TV.

If none of the codes listed for the brand of your TV work, then repeat step 3 several times, using a different code button until one works. The possible code buttons are: 0, 1-9, MUTE, VOLUME \wedge , \vee , CHANNEL \wedge , \vee and INPUT.

You do not need to perform this set-up again until you change the batteries, set up your remote for another brand of television, or you get a new TV.

Once you have correctly set your remote control to operate your TV, you will be able to use the TV POWER, CHANNEL, VOLUME, and number buttons to operate your TV.

IMPORTANT

Because of variations among models, some or all codes may not work, or they may operate different functions than expected for your particular TV. If this occurs, you may need to use your TV remote control.

Sometimes manufacturers will change the remote control codes for their products, or they will use more than one code. If this is the case, your remote may not be able to control your TV.

When you replace the batteries in your remote, the remote may return to its initial setting (code button 1). Repeat the steps above to reset your remote control. If you enter a new code, the previous code will be erased.

operating your TV with the HS-HD1100U remote control

- 1 Set the VCR/TV slide switch to TV position on the HS-HD1100U remote control to tell the remote that you want to operate the TV.
- 2 Point the remote control towards the TV and press the desired buttons. To once again control the VCR, set the VCR/TV slide switch to VCR position.

Brand of TV	Brand code buttons
Mitsubishi	1, 2, 3
Fisher	0
G.E.	VOLUME \wedge
Goldstar	2, 9
Hitachi	8
JVC	MUTE
Magnavox	4
NEC	2, 9
Panasonic	CHANNEL \wedge , \vee
Pioneer	6
Philips	4
Proscan	VOLUME \wedge
Quasar	CHANNEL \vee
RCA	VOLUME \wedge
Sanyo	0
Sharp	3, 5
Sony	VOLUME \vee
Toshiba	7
Zenith	INPUT

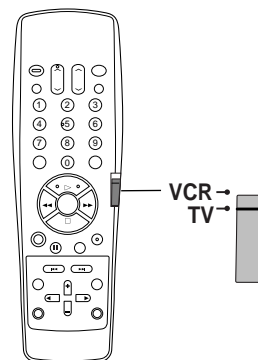

Advanced Features

To program the remote control operational setting

The HS-HD1100U has two remote control operational settings, VCR-A and VCR-B. These are available so you may separately control two Mitsubishi VCRs that are placed close together. The VCR-A setting can be used to operate any other Mitsubishi VCR introduced since 1986. Setting the HS-HD1100U to VCR-B will allow the HS-HD1100U be operated without the VCR responding at the same time.

To program the HS-HD1100U and the remote to VCR-B

For VCR:

- 1 Make sure the HS-HD1100U is plugged in but turned off. On the VCR front panel, turn the shuttle ring left while holding down SP/EP on the front panel. To confirm that the VCR responds to VCR-B signals, **b** appears on the front panel display.

For remote:

- 2 On the remote, make sure the VCR/TV slide switch is in the VCR position, then press VCR/TV and number "2" at the same time. The remote will now send VCR-B signals.

When you wish to operate the other VCR

- 1 On the remote, with the VCR/TV slide switch in the VCR position, press VCR/TV and the number "1" at the same time. The remote will now send VCR-A signals.

To reprogram the HS-HD1100U to respond to VCR-A signals again

- 1 Make sure the HS-HD1100U is plugged in but turned off. On the VCR front panel, turn the shuttle ring right while holding down SP/EP on the front panel. To confirm that the VCR responds to VCR-A signals, **A** appears on the front panel display.

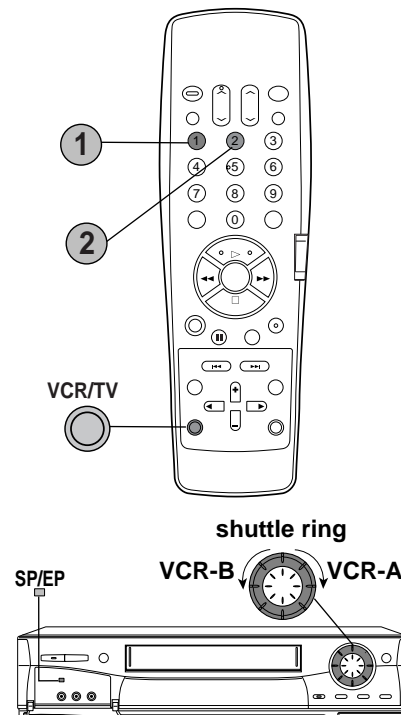

IMPORTANT

Some other models of Mitsubishi VCRs can respond to VCR-B signals. If your other VCR is one of these models, and you would like to program the other VCR to respond to VCR-B signals, refer to the owner's guide that came with the other VCR.

Some of the buttons may not function or they may operate different features than expected for the other VCR, particularly, those Mitsubishi VCR's that are more than 10 years old because Mitsubishi changes the codes from time to time.

Child Lock

The child lock feature prevents others from using your VCR. To lock the VCR:

- 1 Press and hold down DISPLAY on the remote control for about 8 seconds. The LOCK light on the front panel display will light up.
- 2 To cancel the child lock, press and hold down DISPLAY for about 8 seconds, until the LOCK light on the front panel display goes out.

IMPORTANT

You can lock the VCR with the power off, even if the VCR is standing by for a programmed recording. If you lock the VCR with no cassette in it, the VCR will not accept a cassette.

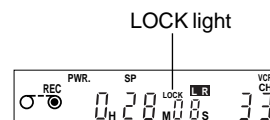

Location of Controls

Remote Control

VCR POWER

Turns the VCR On or Off. If you have programmed the VCR to record, you need to turn the VCR off.

EJECT

Ejects a tape.

CHANNEL Up and Down

Selects next higher or lower channel in the VCR's or TV's channel memory.

VOLUME Up and Down

Raises and lowers the sound of the TV (Operates the TV only).

TV POWER

Turns the TV On or Off. You need to program your remote to operate your particular brand of television.

MUTE

Turns off the TV sound. Press again to restore the TV sound to its previous volume. (Operates the TV only)

Number buttons

Selects TV stations, enters PlusCode numbers. Sets quick search (CM skip) time.

QUICK PROGRAM/VCR Plus+

Goes to VCR Plus+ system menu. Exits the programming screen.

INPUT

Selects between the antenna and any other video equipment that may be connected.

PLAY ▷

Plays a tape.

REW ◀◀

Rewinds a tape or reverse searches.

FF ▶▶

Fast forwards a tape or fast forward searches.

STOP ◻

Stops a tape.

● REC

Starts recording. While recording, adds manual index mark.

PAUSE ||

Pauses a tape when recording.

Freezes a frame when playing a tape.

DISPLAY

Displays on the TV screen:

- Time elapsed on the tape
- Time left on the tape, current time
- Channel number and audio reception mode
- Audio channel(s) selected
- Source supplying the VCR with a signal
- If the VCR is stopped, playing, or recording

Turns the Child Lock on and off.

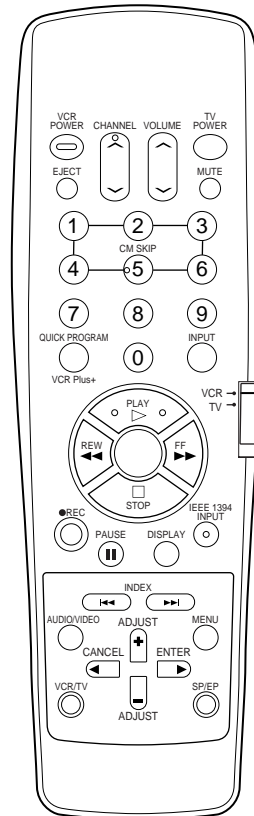

IEEE 1394 INPUT

Selects an integrated HDTV, an IEEE 1394-equipped HDTV receiver or a D-VHS VCR connected to the VCR.

VCR/TV slide switch

Operates the VCR when set to the VCR position, the TV when set to the TV position. You need to program your remote to operate your particular brand of television.

INDEX |◀◀, ▶▶|

Begins index search forward and backward. Controls the playback speed of a tape.

AUDIO/VIDEO

Selects the audio and video settings to be adjusted.

MENU

Displays the menus. Exits the menus.

CANCEL

Cancels selections on the on-screen menus. Resets the counter display to "0H00M00S".

ENTER

Enters selections on the on-screen menus.

ADJUST +, -

Selects and adjusts menu selections.

VCR/TV

Switches between the VCR's picture and the TV's tuner.

SP/EP

Changes the recording speed (SP is standard play; EP is extended play).

Location of Controls

Front Panel

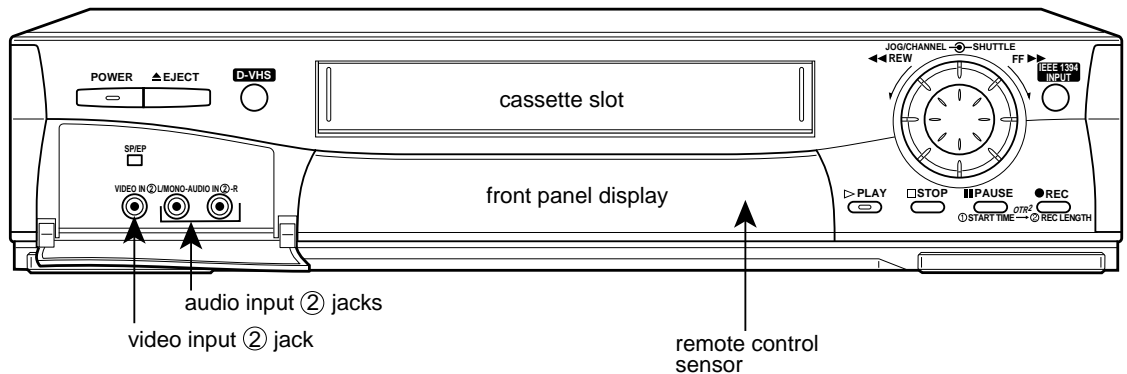

POWER

Turns the VCR On or Off.
If you have programmed your VCR to record, turn off your VCR.

EJECT

Ejects a tape.

D-VHS

Press to choose between recording in digital broadcast in D-VHS format or in VHS format. This button lights up during D-VHS recording/playing.

SP/EP

Changes the recording speed (SP is standard play; EP is extended play).

video input (2) jack

Connect source here, such as a VCR or camcorder, to record or dub video.

audio input (2) jacks

Connect source here, such as a VCR or camcorder, to record or dub audio.

cassette slot

Insert the video cassette tape here.

front panel display

See the next page.

remote control sensor

Receives signals from the remote control.
Do not block it.

JOG/CHANNEL

Changes channels when tape is stopped.
Adjusts tracking and picture vibration.

SHUTTLE ring

Fast forwards a tape or fast forward searches by turning right. Rewinds a tape or reverse searches by turning left.

IEEE 1394 INPUT

Selects an integrated HDTV, an IEEE 1394-equipped HDTV receiver or a D-VHS VCR connected to the VCR.

▶ PLAY

Plays a tape.
Resumes normal playback from special effects.

□ STOP

Stops a tape.

|| PAUSE/① START TIME

Pauses a tape when recording.
Freezes a frame when playing a tape.
Sets the start time in OTR² recording.

● REC/② REC LENGTH

Records to the end of the tape by pressing once.
Sets the recording time for OTR recording by pressing repeatedly.

Location of Controls

Front Panel Display

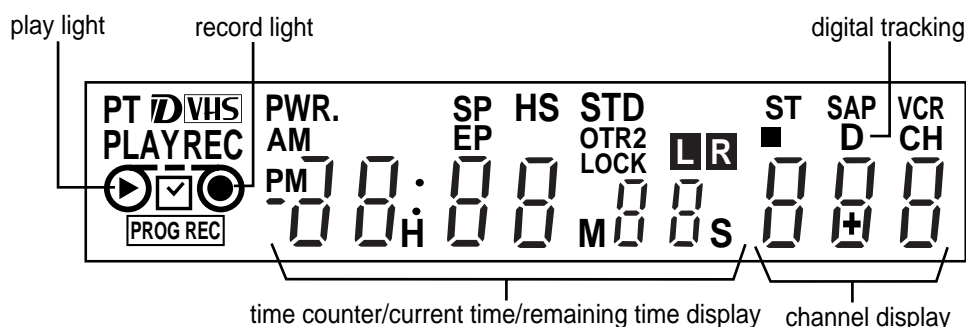

PerfectTape® light : PT

Flashes when PerfectTape test is in progress.
Stays lit when test is complete.

D-VHS indicator :

Lights up when D-VHS playing/recording.

play and record lights : **PLAY REC**

These light up when the VCR is playing a tape or recording. The cassette status symbol () will light up when a tape is in the VCR. The dashes in the center of the symbol simulate the movement of the tape when playing and recording.

programmed recording light :

Lights up when VCR is off and it is programmed to record.

POWER light : PWR.

Is lit when power is ON.

tape speed lights : SP, EP, HS, STD

Indicates tape speed.

time counter/current time/remaining time display

This area displays:

- current time
- time counter showing how long tape has run
- time remaining on the tape

OTR light : OTR

Lights up during recording the program with One-Touch Recording.

OTR2 light : OTR 2

Lights up during setting up, the delay time of Standby One-Touch Recording.

lock light : LOCK

Lights up when Child Lock feature is in use.

LR indicator :

L indicates that you are listening to the left channel of a stereo track, R indicates that you are listening to the right channel of a stereo track.

stereo indicator : ST

Indicates a stereo TV channel.

cable tuning light :

Lights up when VCR is set to receive cable broadcasts.

SAP indicator : SAP

Indicates that channel has a Separate Audio Program or SAP.

digital tracking light : D

Flashes when VCR is adjusting the tracking.
Glows steadily when tracking is finished.
If tracking is adjusted manually, it turns off.

VCR light : VCR

Indicates that the picture is controlled by the VCR.

channel display

Displays cable channel, broadcast channel or input.

Location of Controls

Rear Panel Jacks

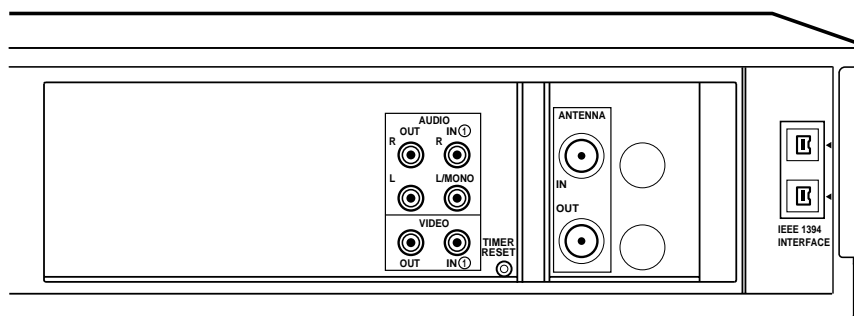

VIDEO INput and OUTput jacks

Yellow jacks are for receiving (IN) and sending (OUT) video signals to a monitor TV or from another VCR.

AUDIO INput and OUTput jacks

Red and white jacks are for receiving (IN) and sending (OUT) audio signals. Red signifies the right channel, and white signifies the left channel. Stereo audio cables are also color coded red and white. If you are receiving or sending a mono (non-stereo) signal, you should use only the left (white) terminal.

TIMER RESET

Erases all programmed recording settings and resets the clock. Use this button with care.

ANTENNA IN jack

Attach an external antenna or cable to bring in an outside signal.

ANTENNA OUT jack

Attach a coaxial cable to your TV to send out antenna/cable signals from the VCR to your TV.

IEEE 1394 INTERFACE

Connects an IEEE 1394 cable to an integrated HDTV or an IEEE 1394-equipped HDTV receiver for D-VHS recording/playback.

Important Information

Special Information Concerning Stationary Images or Letterbox Images:

For best performance and longest life, the normal use of a TV should include a mixture of TV picture types. The most frequently used picture types should fill the screen with constantly moving images rather than stationary images or patterns. Displaying the same stationary patterns over extended periods of time or displaying the same stationary patterns frequently, can cause uneven aging of the TV picture tubes and leave a subtle, but permanent, ghost image. Most TV warranties do not cover this type of damage to the picture tubes. To avoid this, mix your viewing pattern. Do not show the same stationary image for more than 15% of your total TV viewing in any one week. Display constantly moving and changing images that fill the screen whenever possible. We also recommend that you reduce the contrast setting of your TV when you watch that type of image. When possible, you may wish to use your television's PIP, POP, ZOOM, EXPAND or other picture shape controls so that the moving images fill the screen.

Please check your TV's owner's guide for other recommendations.

Examples of stationary images include:

- **Letterbox top/bottom bars.** These are solid colored bars that when showing a widescreen (16:9) image on a standard (4:3) TV.
- **Side panels.** These are the solid colored side bars when showing standard shaped (4:3) TV images on a widescreen (16:9) TV.
- **Stock-market report bars.** These include the ticker bar constantly running at the bottom of the TV screen on financial news channels.
- **Shopping channel logos & pricing displays.** These include bright graphics that are shown constantly or repeatedly in the same location.
- **Video game patterns and scoreboards.**
- **Bright station logos.** Moving or low-contrast graphics are less likely to cause uneven aging of the picture tubes.
- **Online (Internet) web sites.** In addition, any other stationary or repetitive computer style images from any source may cause uneven aging of the picture tubes.

Trouble Checks

If your VCR malfunctions, try the following steps prior to contacting your Mitsubishi Dealer:

- 1 Check the **Trouble Checks** below to see if there is a solution to the current problem that you are experiencing.
- 2 If the problem is not addressed on the **Trouble Checks**, the safety circuits in the VCR may be in operation, thus please try the following: (the clock setting and the timer recording will be deleted.)
 - 1 If possible, press EJECT on the front panel and remove the tape.
 - 2 Press TIMER RESET on the rear panel with a pencil or a ball point pen.
 - 3 If a tape is not loaded, press POWER to turn the power on. If a tape is loaded, wait about 1 minute until the tape protecting function is complete, then press POWER.
- 3 You may also try the following procedure if the above steps did not resolve the problem (All settings will be reset to the default settings.).
 - 1 Press POWER on the front panel for about 8 seconds until “” appears on the front panel display.
 - 2 If a tape is not loaded, press POWER to turn the power on. If a tape is loaded, the tape protecting function will work and “99” will appear on the front pane display to begin count down. Wait about 1 minute until it reaches “00” to show the tape protecting function is complete, then press POWER.

If the problem with your VCR persists, contact your Mitsubishi dealer for assistance.

Problem

Try This...

The VCR won't turn on.

- Check the power cord and the AC outlet.
- Is the LOCK light ON? If so, press and hold DISPLAY on the remote for more than 8 seconds until the LOCK light turns off.

The VCR power is on but no controls work.

- Is the LOCK light ON? If so, press and hold DISPLAY on the remote for more than 8 seconds until the LOCK light turns off.
- Set the VCR/TV slide switch to VCR position.
- Press TIMER RESET on the rear panel.

You can't see the VCR's picture on your TV.

- Check the TV's input setting.
- Check to see that your VCR is not set to **L1** or **L2**.

Poor picture when watching the VCR's tuner on your TV.

- Check to see if your TV is set to the correct channel or input.
- Check your TV's fine tuning, if using an older TV.
- Check your connections to make sure they are secure.

VCR REC button doesn't function.

- Check the erasure prevention tab on the tape cassette.

No picture during recording.

- Check the hook-up.
- Check to see if your TV is set to the correct channel or input.

VCR does not record TV program.

- Check the VCR tuning.
- Check the input selection on the VCR. Does the front panel display show **L1** or **L2**? If so, switch it to tuner by pressing INPUT.

The VCR timer recording does not operate.

- Check that the programmed recording light lights up on the front panel display.
- Check the clock time.
- Make sure you have turned the VCR off before the start time.
- For D-VHS timer recording:
 - Check the IEEE 1394 connection.
 - Is an integrated HDTV or an IEEE 1394-equipped HDTV receiver turned on?
 - Have you programmed the timer recording on an integrated HDTV or an IEEE 1394-equipped HDTV receiver?
 - The program prohibited from copying cannot be recorded.

Noise in the picture and distorted sound.

- Check the tracking control. Adjust manually if necessary.

Poor or no Hi-Fi sound.

- Check the monitor settings.
- Check the quality of the video tape.

Trouble Checks

Problem

Try This...

Playback is noisy or “snowy.”

- Try automatic head cleaning.
- Clean the video heads using a dry-type video head cleaning cassette. Do not use a wet-type head cleaning cassette, as it may damage your VCR. Excessive use of a cleaning cassette could shorten head life. Follow the cleaning instructions carefully.
- Have the VCR video heads cleaned by a qualified service technician.

VCR remote does not function.

- Check that the remote mode of the VCR and your remote are set correctly (VCR-A or VCR-B).
- Check to see that the VCR/TV slide switch is set to the correct position.
- Change the batteries.

The fast forwarding/rewinding speed is slow.

- In order to protect your tapes and the VCR heads, the Fast Forwarding/Rewinding Speed will be slower than 500x under the following conditions:
 - 1 Use of tapes shorter in length than T-120 (for example, T-30, T-60, T-90).
 - 2 Use of tapes longer in length than T-120 (for example, T-160, T-180, T-210. Also for DF-300, DF360, DF-420, and DF-480).
 - 3 Activating fast forwarding or rewinding from the middle of the tape.

You cannot playback or record in D-VHS.

- Be sure to use the D-VHS tape for D-VHS recording.
- You may not be able to record programs which have copy protect data to prohibit or restrict recording. If you record such programs, no COPY will appear on the front panel display.
- Try the followings:
 - Pull off the IEEE 1394 cable, and leave it unplugged for few seconds, then plug it again.
 - Turn the power on/off of the IEEE 1394-equipped device which is connected to the VCR.
 - If it is equipped, press the RESET button on the IEEE 1394-equipped device which is connected to the VCR.
 - Turn off the power of the VCR and the IEEE 1394-equipped device which is connected to the VCR, then plug out/in the power cord of each device.

A mosaic noise, still or black picture appears when playback or speed search the tape recorded in D-VHS.

- When you playback the end of a recording, the point where the recording mode changes or a broken part of the tape, a mosaic noise, still or black picture may appear.
- The block noise may appear during speed search of the tape recorded in D-VHS.
- Clean the video heads using a dry-type video head cleaning cassette. Do not use a wet-type head cleaning cassette, as it may damage your VCR. Excessive use of a cleaning cassette could shorten head life. Follow the cleaning instructions carefully.
- Have the VCR video heads cleaned by a qualified service technician.
- The program recorded with the Search w/ Picture in the Customize Choices menu is set to OFF may not be searched correctly.

No picture or sound from the IEEE 1394-equipped device.

- Check the hook-up.
- When you connect more than one IEEE 1394-equipped devices, turn the power off when they are not being used because leaving the unused devices turned on may cause a lack of memory and may interfere with the correct transmission of signals.
- You cannot send/receive the data of digital video equipment (for example, digital video camera) or a personal computer because the format is different from that of the HS-HD1100U.
- Is an integrated HDTV or an IEEE 1394-equipped HDTV receiver turned on?

Specifications

FORMAT	VHS NTSC standard with Hi-Fi audio and D-VHS standard
VIDEO SIGNAL SYSTEM	EIA standard; NTSC color
RECORD/PLAYBACK SYSTEM	Video -- 4 heads Audio -- 2 Hi-Fi channels and 1 monaural audio control Digital -- HS 4 heads STD 2 heads
ANTENNA	75-ohm external VHF/UHF combined antenna terminal
TUNER	181 channels capability VHF -- Channels 2 - 13 UHF -- Channels 14 - 69 CATV -- Channels 1-125
DIGITAL INTERFACE INPUT/OUTPUT	based on IEEE 1394 digital interface, 4 pin, corresponds to S400
HORIZONTAL RESOLUTION	more than 220 lines (SP) more than 210 lines (EP)
SIGNAL-TO-NOISE RATIO	more than 45 dB (SP) more than 46 dB (EP)
TIMER PROGRAM CAPACITY	1-month programmable / 8 programs
MEMORY BACKUP TIME	approx. 30 minutes
MAXIMUM RECORDING TIME (D-VHS)	150 min. with DF-300 video cassette (HS)
	300 min. with DF-300 video cassette (STD)
	120 min. with T-120 video cassette (SP)
	360 min. with T-120 video cassette (EP)
	approx. 43 seconds for T-120 cassette
REWIND TIME	
POWER REQUIREMENT	120V AC, 60 Hz
POWER CONSUMPTION	25 Watts -- 6.0 Watts standby
DIMENSIONS	3.7 in Height x 16.7 in Width x 12.0 in Depth (93mm x 425mm x 306mm)
WEIGHT	9.5 lbs approx. (4.3kg)
SUPPLIED ACCESSORIES	1 set coaxial cable 1 set audio/video cable 1 IEEE 1394 cable 1 remote control with batteries 1 registration card

Index

A		B		child lock	51
adding channels	16	backup, memory	37	choosing a hookup	4
adjusting tracking	43	batteries, installing	12	clock setting	17
advanced options	50	C		CM skip	44
playback controls	42	cable, connections to	5	connections to	
antenna, connecting	5	cable box, connections to	5, 6	antennas	5
jacks	5, 55	cable tuning light	54	cable with or without box	5, 6
audio		cancel button	52	home theater receiver	10
connecting a TV with inputs	7	cancel		integrated HDTV or IEEE 1394-	
input, output jacks	53, 55	button	52	equipped HDTV receiver	8
monitor	26	recording in progress	32	TV w/audio video inputs	7
audio video functions		timer recording	32, 37	copying a tape	
button	52	cassette slot	53	from D-VHS to D-VHS	38
selecting	27	cassette status symbol	54	from D-VHS to analog	39
using	26	changing recording settings	36	from analog to analog	40
auto clock function	17	changing settings while		counter display	43
auto power save	48	programming	32	counter zero stop	27, 45
auto speed programming	35	channel(s)		customize choices menu	47
		adding and deleting	16		
		display	54		
		memorize	15		
		selecting	16		

Index

D	
daylight savings time	18
digital tracking light	54
display button	52
displaying current time	47
displaying time gauge	46
D-VHS	
button	53
indicator	54
tape setting	27
E	
editing features	38
eject button	52, 53
enter button	52
erasure, preventing tape	20
F	
fast forwarding a tape	14, 44
FF button	52
front panel buttons	53
front panel display	53, 54
H	
head cleaning	14
I	
IEEE 1394	
connection	8
INPUT button	52, 53
INTERFACE jacks	8, 55
notes about network	9
1394 connection list	11
important safeguards	2
index buttons	52
techniques	45
INPUT button	52
J	
JOG/CHANNEL	53
L	
loading tapes	13
location of controls	52
lock light	51, 54
lock VCR	51
LR indicator	54
M	
memory backup	37
menu button	52
menus, using	15
mute button	52
N	
number buttons	52
normal recording	26
O	
one touch recording (OTR)	23
light	54
one touch recording, standby	24
light (OTR 2)	54
P	
pause button	52, 53
pausing a tape	14
PerfectTape® light	54
using	27, 48
PerfectTape Select	27
play and record lights	54
play button	52, 53
play a tape	13
playback controls, advanced	42
power button	53
program caution	36
programmed recording light	54
programming	
auto speed	35
cancel	32, 37
changing settings while	32
Q	
quick program	34
QUICK PROGRAM/VCR Plus+	
button	52
quick search	44
R	
rear panel jacks	55
rec button	52, 53
record cancel	32
record light	54
recording	
analog timer recording of digital	
broadcast	22
canceling programmed	37
canceling one in progress	32
conventional VCR timer	31
current digital broadcast	20
current broadcast in analog format	
.....	22
D-VHS timer	28
format	25
mode	25
one-touch	23
Quick Program	34
standby one-touch	24
time	25
timer	28
VCR Plus+ system	33
remote control	
buttons	52
sensor	53
RentalXpress	49
repeat playback	27, 46
rew button	52
rewinding a tape	14, 44
RF converter setting	48

S	
S-VHS quasi playback	13
SAP indicator	54
SAP broadcast	26
search techniques	43
search to blank	27, 46
setting the clock	17
shuttle ring	53
skipping programs	36
special effects	42
SP/EP button	52, 53
stereo indicator	54
stop button	52, 53
T	
tape function	27
D-VHS	27
tape speed lights	54
tape	
copying	38
loading	13
playing	13
repeating	27, 46
television, connecting	7, 8
operating with remote	50
time	
counter	43
display current	47
gauge	46
remaining	46
timer recording	28
timer reset button	37, 55
tracking	43
trouble checks	57
TV POWER button	52
TV/VCR slide switch	52
V	
VCR	
light	54
operating 2 w/ 1 remote	51
setting up	15
VCR POWER button	52
VCR/TV button	52
video	
input, output jacks	53, 55
mute	47
volume button	52

Warranty

MITSUBISHI VIDEO CASSETTE RECORDER LIMITED WARRANTY

MITSUBISHI DIGITAL ELECTRONICS AMERICA, INC. (MDEA) warrants to the original purchaser of this video cassette recorder if purchased from an authorized MITSUBISHI Audio/Video Dealer that, should it prove defective by reason of improper workmanship and/or material:

- a. **Parts.** For one year from the date of original purchase at retail, we will repair or replace, at our option, any defective part including the video head without charge for the part. Parts used for replacement are warranted for the remainder of the original warranty period.
- b. **Labor.** For ninety days from the date of original purchase at retail, we will provide the labor for a warranty repair without charge at an authorized MITSUBISHI service center.
- c. **Notice.** To obtain warranty service, you must notify an authorized MITSUBISHI service center of any defect within the applicable warranty time period.

- 1 TO OBTAIN WARRANTY SERVICE, deliver your VCR to the nearest MITSUBISHI service center. Shipping expenses are your responsibility. The name and address of the nearest service center can be obtained from your MITSUBISHI Dealer, or by writing or calling MDEA at the address and telephone number below. Proof of purchase date from an authorized MITSUBISHI Dealer is required when requesting warranty service. Present your sales receipt or other document which establishes proof and date of purchase. THE RETURN OF THE OWNER REGISTRATION CARD IS NOT A CONDITION OF WARRANTY COVERAGE. However, please detach and return the Owner Registration Card so that we can contact you should a question of safety arise which could affect you.
- 2 THIS WARRANTY DOES NOT COVER damage caused by: modification, alteration, repair or service of this product by anyone other than an authorized MITSUBISHI service center; physical abuse to, or misuse of, the VCR; operation in a manner contrary to the instructions which accompany the VCR; freight damage; or any damage caused by acts of God such as lightning or fluctuation in electrical power. This warranty also excludes all costs arising from installation, adjustment of user controls, external antenna systems, service of products purchased or serviced outside the U.S.A., initial technical adjustments (set-up) and user-required maintenance including head cleaning. Consult the operating instructions enclosed with the product for information regarding user controls.
- 3 ANY EXPRESS WARRANTY NOT PROVIDED HEREIN, AND ANY REMEDY WHICH, BUT FOR THIS PROVISION, MIGHT ARISE BY IMPLICATION OR OPERATION OF LAW, IS HEREBY EXCLUDED AND DISCLAIMED. THE IMPLIED WARRANTIES OF MERCHANTABILITY AND OF FITNESS FOR ANY PARTICULAR PURPOSE ARE EXPRESSLY LIMITED TO A TERM OF ONE YEAR.
- 4 UNDER NO CIRCUMSTANCES SHALL MDEA BE LIABLE TO PURCHASER OR ANY OTHER PERSON FOR ANY INCIDENTAL, SPECIAL OR CONSEQUENTIAL DAMAGES, WHETHER ARISING OUT OF BREACH OF WARRANTY, BREACH OF CONTRACT, OR OTHERWISE.
- 5 Some states do not allow limitations on how long an implied warranty lasts, or the exclusion or limitation of incidental, special, or consequential damages, so the above limitations or exclusions may not apply to you.
- 6 This warranty gives you specific legal rights and you may also have other rights which vary from state to state.
- 7 BEFORE REQUESTING SERVICE, please review the instruction booklet to insure proper installation and correct customer control adjustment. If the problem persists, contact your nearest MITSUBISHI Dealer for name(s) of authorized MITSUBISHI Service Center(s). If you are unable to obtain the information, please call 1-800-332-2119, or write us at the address below.

MITSUBISHI DIGITAL ELECTRONICS AMERICA, INC.
9351 Jeronimo Road
Irvine, CA 92618-1904



RETAIN THIS PORTION FOR YOUR RECORDS

SERIAL NO. _____

CUSTOMER NAME _____

STREET ADDRESS _____

CITY _____ STATE _____ ZIP _____

PHONE (____) _____ PURCHASE DATE ____ / ____ / ____

MO DAY YR

PLACE OF PURCHASE _____

PHONE (____) _____

For your nearest Mitsubishi Authorized Service Center
call 1-800-332-2119

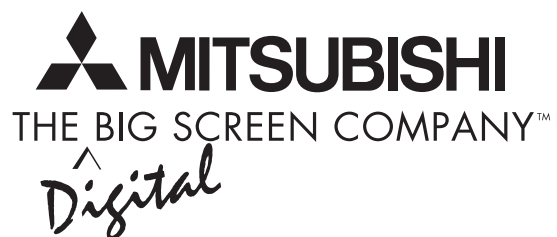

MITSUBISHI DIGITAL ELECTRONICS AMERICA, INC.
9351 Jeronimo Road
Irvine, CA 92618-1904
www.mitsubishi-tv.com

© 2002 Mitsubishi Digital Electronics America, Inc.

Printed in Japan
872C246A5